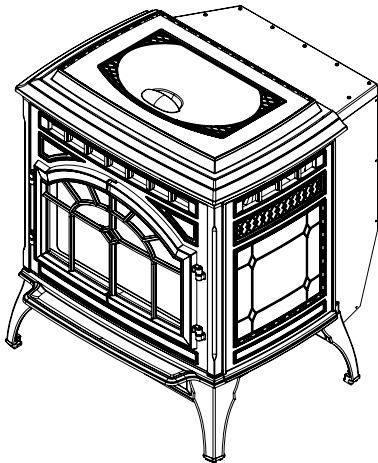


# QUADRA-FIRE®

## MT. VERNON PELLET STOVE ADVANCED ENERGY (AE)



### Owner's Manual Installation and Operation

#### Models:

MTVERNON-AE-MBK

MTVERNON-AE-PMH

MTVERNON-AE-CSB

MTVERNON-AE-CWL

Tested and  
Listed by  Portland  
Oregon USA  
C US  
OMNI-Test Laboratories, Inc.



### NOTICE

#### DO NOT DISCARD THIS MANUAL



- Important operating and maintenance instructions included.
- Read, understand and follow these instructions for safe installation and operation.
- Leave this manual with party responsible for use and operation.



### WARNING



Please read this entire manual before installation and use of this pellet fuel-burning room heater. Failure to follow these instructions could result in property damage, bodily injury or even death.

- Do not store or use gasoline or other flammable vapors and liquids in the vicinity of this or any other appliance.
- Do not overfire - If any external part starts to glow, you are overfiring. Reduce feed rate. Overfiring will void your warranty.
- Comply with all minimum clearances to combustibles as specified. Failure to comply may cause house fire.



### WARNING



#### HOT SURFACES!

Glass and other surfaces are hot during operation AND cool down.

#### Hot glass will cause burns.

- Do not touch glass until it is cooled
- NEVER allow children to touch glass
- Keep children away
- CAREFULLY SUPERVISE children in same room as fireplace.
- Alert children and adults to hazards of high temperatures.

#### High temperatures may ignite clothing or other flammable materials.

- Keep clothing, furniture, draperies and other flammable materials away.


### CAUTION

Tested and approved for wood pellets, shelled field corn, wheat and black oil sunflower seeds. Burning of any other type of fuel voids your warranty.

### CAUTION

Check building codes prior to installation.

- Installation MUST comply with local, regional, state and national codes and regulations.
- Consult local building, fire officials or authorities having jurisdiction about restrictions, installation inspection, and permits.

*Congratulations*   
and Welcome to the Quadra-Fire Family!

Hearth & Home Technologies welcomes you to our tradition of excellence! In choosing a Quadra-Fire appliance, you have our assurance of commitment to quality, durability, and performance.

This commitment begins with our research of the market, including 'Voice of the Customer' contacts, ensuring we make products that will satisfy your needs. Our Research and Development facility then employs the world's most advanced technology to achieve the optimum operation of

our stoves, inserts and fireplaces. And yet we are old-fashioned when it comes to craftsmanship. Each unit is meticulously fabricated and surfaces are hand-finished for lasting beauty and enjoyment. Our pledge to quality is completed as each model undergoes a quality control inspection.


We wish you and your family many years of enjoyment in the warmth and comfort of your hearth appliance.

Thank you for choosing Quadra-Fire.

**NOTE: Consult insurance carrier, local building inspector, fire officials or authorities having jurisdiction over restrictions, installation inspection and permits.**

**LOCATION OF SERIAL NUMBER / SAFETY LABEL: Back of Stove**

Serial No.                      Model Name



**ATTENTION: CHAUD LORS DE L'OPÉRATION. NE PAS TOUCHER. GARDEZ LES ENFANTS ET LES VÊTEMENTS LOIN DE L'ESPACE DESIGNÉ DE L'INSTALLATION. LE CONTACT PEUT CAUSER DES BRÛLURES À LA PEAU. VOIR**

**ESPACES LIBRES MINIMUM DES MATÉRIEAUX COMBUSTIBLES:**

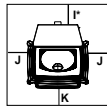
A 2 in. (51mm)	E 6 in. (152mm)
B 6 in. (152mm)	F 8 in. (203mm)
C 2 in. (51mm)	G 3 in. (76mm)
D 3 in. (76mm)	

**INSTALLATION DE L'ALCÔVE**  
 Une hauteur minimum de l'alcôve: 43 in. (1092mm)  
 Une hauteur minimum mur de l'alcôve: 6 in. (152mm)  
 Une épaisseur minimum mur de l'alcôve: 40 in. (1016mm)  
 La profondeur maximum de l'alcôve: 36 in. (914mm)

Note 1: Dans les installations résidentielles, lorsque les pièces TPVNT-MV, (dessus de l'adaptateur de ventilation 3 in. - 3 in.) et 812-3570 (le ressort de l'adaptateur 3 in. - 6 in.), un tuyau connecteur de 6 in. pour mur simple calibre 24 peut être utilisé.

Note 2: Pour l'installation dans les maisons préfabriquées, lorsque les pièces TPVNT-MV, (dessus de l'adaptateur de ventilation 3 in. - 3 in.) et 812-3570 (le ressort de l'adaptateur 3 in. - 6 in.), utilisez un tuyau connecteur enregistré pour mur double. Un assemblage d'air extérieur (pièce 811-0872), doit être utilisé pour l'installation dans les maisons préfabriquées.

**PROTECTION DU SOL**

I* = 2 in. (51mm)	
J = 2 in. (51mm)	
K = 6 in. (152mm)	

**MINIMUM CLEARANCES TO COMBUSTIBLE MATERIALS**

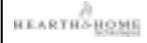
Listed Solid Fuel Room Heater/Pellet Type Stove. Also suitable for Mobile Home Installation. This appliance has been tested and listed for use in Manufactured Homes in accordance with OAR 814-23-9000 through 814-23-9005.

Tested to: ASTM E1509-04, ULC S627.00, ULC/ORD-C1482-M1990 Room Heating Pellet Burning Type, (UM) 84-HUD FOR USE ONLY WITH PELLETIZED WOOD. See Owner's Manual for other fuel options.

Input Rating: 60,000 BTU/s/hr. Electrical Rating: 115 VAC, 60 Hz, Start 5 Amps, Run 1.25 AMPS.

Route power cord away from unit. Do not route cord under or in front of appliance.

**DANGER:** Risk of electrical shock. Disconnect power supply before servicing. Replace glass only with 5mm ceramic available from your dealer. To start, set thermostat above room temperature, the stove will light automatically. To shutdown, set thermostat to below room temperature. For further instruction refer to owner's manual. Keep viewing and ash removal doors tightly closed during operation.

Manufactured by / Fabriqué par:  
  
 1445 Highway North,  
 Colville, WA 99114  
 www.quadrafire.com  
 Made in the USA  
 Fait-Aux États-Unix

**DO NOT REMOVE THIS LABEL  
 NE PAS ENLEVER L'ÉQUETTE**

**ALCOVE INSTALLATION:**

Min. Alcove Height: 43 in. (1092mm)  
 Min. Alcove Side Wall: 6 in. (152mm)  
 Min. Alcove Width: 40 in. (1016mm)  
 Max. Alcove Depth: 36 in. (914mm)

A 2 in. (51mm)  
 B 6 in. (152mm)  
 C 2 in. (51mm)  
 D 3 in. (76mm)  
 E 6 in. (152mm)  
 F 8 in. (203mm)  
 G 3 in. (76mm)

Note 1: In residential installations, when using Parts TPVNT-MV, (3 in. - 3 in. Top Vent Adapter) and 812-3570 (3 in. - 6 in. Offset Adapter), 24 gauge 6 in. Single wall flue connector may be used.

Note 2: In manufactured home installation, when using Part TPVNT-MV, (3 in. - 3 in. Top Vent Adapter) and 812-3570 (3 in. - 6 in. Offset Adapter), use listed double wall flue connector. An Outside Air Kit (Part 811-0872), must be used with manufactured home installation.

**FLOOR PROTECTION**

I\* = 2 in. (51mm)  
 J = 2 in. (51mm)  
 K = 6 in. (152mm)

Use a non-combustible floor protector, extending beneath heater and to the front/sides/rear as indicated. Measure front distance (K) from the surface of the glass door.

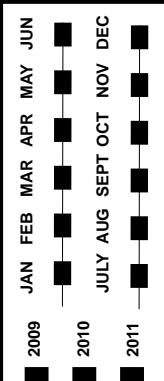
\*Non-combustible floor protection must extend beneath the flue pipe when installed with horizontal venting or under the Top Vent Adapter with vertical installation. RECOMMENDED IN USA


**QUADRA-FIRE**

Mt. Vernon Pellet Stove AE

SERIAL NO. / NUMÉRO DU

**007001**



Tested and Listed by  Portland Oregon USA  
 C-T-L US  
 CTR Fire Laboratories, Inc.

Report / Rapport  
 061-S-68-6

7034-107B

Mfg Date                      Test Lab & Report No.

**Safety Alert Key:**

- **DANGER!** Indicates a hazardous situation which, if not avoided will result in death or serious injury.
- **WARNING!** Indicates a hazardous situation which, if not avoided could result in death or serious injury.
- **CAUTION!** Indicates a hazardous situation which, if not avoided, could result in minor or moderate injury.
- **NOTICE:** Indicates practices which may cause damage to the appliance or to property.

**TABLE OF CONTENTS**

**Section 1: Listing and Code Approvals**

- A. Appliance Certifications .....4
- B. Mobile Home Approved .....4
- C. Glass Specifications.....4
- D. Electrical Rating .....4
- E. Specifications.....4

**Section 2: Getting Started**

- A. Design, Installation & Location Considerations.....5
- B. Thermostat Wall Control Location .....6
- C. Tools & Supplies Needed .....6
- D. Inspect Appliance & Components.....6
- E. Pre-Use Check List.....6

**Section 3: Dimensions & Clearances**

- A. Appliance Dimensions .....7
- B. Clearances to Combustibles .....8
- C. Hearth Pad Requirements .....8

**Section 4: Vent Information**

- A. Venting Termination Requirements ....9
- B. Avoiding Smoke and Odors .....10
- C. Negative Pressure.....11
- D. Draft.....11
- E. Chimney & Exhaust Connection.....12
- F. Equivalent Meter of Pipe.....12
- G. Pipe Selection Chart.....13

**Section 5: Venting Systems**

- A. Alcove .....14
- B. Through the Wall.....15
- C. Vertical into Class A Chimney.....16
- D. Through the Wall & Vertical-Exterior... 16
- E. Vertical-Interior.....16
- F. Masonry .....17
- G. Alternate Masonry.....17

**Section 6: Mobile Home Installation.....18**

**Section 7: Appliance Set-Up**

- A. Leg Leveling System .....19
- B. Outside Air Kit.....19
- C. Top Vent Adapter.....20
- D. Rear Vent Adapter .....20
- E. Log Set Placement.....21
- F. Thermostat Wall Control Installation ...22

**Section 8: Operating Instructions**

- A. Fire Safety .....23
- B. Combustible/Non-Combustible .....23
- C. Fuel Size, Material & Storage .....23-24
- D. General Operation Information .....24
- E. Before Your First Fire .....25
- F. Filling the Hopper with Fuel .....25
- G. Starting Your First Fire.....25
- H. Fire Characteristics & Flame Height Adjustment.....25
- I. Battery Back-Up System.....26
- J. Clear Space .....26
- K. Ignition Cycles .....27-28
- L. Quick Start Guide .....29-30
- M. Frequently Asked Questions.....31

**Section 9: Troubleshooting .....32**

**Section 10: Maintaining & Servicing Appliance**

- A. Proper Shutdown Procedures.....33
- B. Quick Reference Maintenance Chart..33
- C. General Maintenance & Cleaning .....34-38
- D. High Ash Fuel Content Maintenance ..39
- E. Baffle Removal.....39
- F. Convection Blower Replacement.....40
- G. Combustion Blower Replacement.....41
- H. Glass Replacement.....41

**Section 11: Reference Materials**

- A. Component Functions.....42-43
- B. Component Locations.....44
- C. Exploded Drawings.....45-46
- D. Service Parts & Accessories .....47-51
- E. Service & Maintenance Log .....52-53
- F. Warranty Policy .....54-55
- G. Contact Information.....56

## 1

## Listing and Code Approvals

## A. Appliance Certification

<b>Model</b>	Mt. Vernon Pellet Stove AE
<b>Laboratory</b>	OMNI Test Laboratories, Inc.
<b>Report No.</b>	061-S-68-6
<b>Type</b>	Solid Fuel Room Heater/Pellet Fuel BurningType
<b>Standard</b>	ASTM E1509-04, ULC S627-00 and ULC/ORD-C1482-M1990 Room Heater Pellet Fuel Burning type and (UM) 84-HUD, Mobile Home Approved.
<b>FCC</b>	Complies with Part 15 of FCC Rules. Operation is subject to the following two conditions: (1) this device may not cause harmful interference, and (2) this device must accept any interference received, including interference that may cause undesired operation.

**NOTICE:** This installation must conform with local codes. In the absence of local codes you must comply with the **ASTM E1509-04, ULC S627-00, (UM) 84-HUD and ULC/ORD-C-1482.**

## B. Mobile Home Approved

This appliance is approved for mobile home installations when not installed in a sleeping room and when an outside combustion air inlet is used.

The structural integrity of the mobile home floor, ceiling, and walls must be maintained.

The appliance must be properly grounded to the frame of the mobile home and use only Listed pellet vent Class "L" or "PL" connector pipe.

A Quadra-Fire Outside Air Kit must be installed in a mobile home installation. You must order the Outside Air Kit separately.

**Note:** The appliance is also approved for installation into a shop.

## C. Glass Specifications

This appliance is equipped with 5mm ceramic glass. Replace glass only with 5mm ceramic glass. Please contact your dealer for replacement glass.

## D. Electrical Rating

115 VAC, 60 Hz, Start 5 Amps, Run 1.25 Amps

## E. BTU &amp; Efficiency Specifications

<b>Emissions Rating:</b>	EPA Compliance
<b>*BTU Output:</b>	14,620 - 60,200 / hr
<b>Efficiency:</b>	81.4% - 83.6%
<b>Heating Capacity:</b>	2,400 - 3,800 square feet depending on climate zone
<b>Hopper Capacity:</b>	81 lbs
<b>Fuels:</b>	Pellets, Shelled Field Corn, Wheat and Black Sunflower Seeds
<b>Shipping Weight:</b>	429 lbs

\*BTU will vary, depending on the type of fuel you use in your appliance. Consult your Quadra-Fire dealer for best results.

**WARNING! Risk of Fire!** Hearth & Home Technologies disclaims any responsibility for, and the warranty and agency listing will be voided by the above actions.

**DO NOT:**

- Install or operate damaged appliance
- Modify appliance
- Install other than as instructed by Hearth & Home Technologies
- Operate the appliance without fully assembling all components
- Overfire
- Install any component not approved by Hearth & Home Technologies
- Install parts or components not Listed or approved.

Improper installation, adjustment, alteration, service or maintenance can cause injury or property damage.

For assistance or additional information, consult a qualified installer, service agency or your dealer.

**NOTICE:** Hearth & Home Technologies, manufacturer of this appliance, reserves the right to alter its products, their specifications and/or price without notice.

Quadra-Fire is a registered trademark of Hearth & Home Technologies.

# 2

## Getting Started

### A. Design, Installation & Location Considerations

#### 1. Appliance Location

**NOTICE:** Check building codes prior to installation.

- Installation MUST comply with local, regional, state and national codes and regulations.
- Consult insurance carrier, local building inspector, fire officials or authorities having jurisdiction over restrictions, installation inspection and permits.

It is a good idea to plan your installation on paper, using exact measurements for clearances and floor protection, before actually beginning the installation. Location of the appliance and chimney will affect performance.

Consideration must be given to:

- Safety, convenience, traffic flow
- Placement of the chimney and chimney connector and to minimize the use of chimney offsets.
- Place the appliance where there will be a clear passage for a Listed chimney through the ceiling and roof (vertical) or through exterior wall (horizontal).
- Installing the required outside air kit will affect the location of the vent termination.

When locating vent and venting termination, the ideal location is to vent above roof line when possible. This minimizes the affects of wind loading.

Since pellet exhaust can contain ash, soot or sparks, you must consider the location of:

- Windows
- Air Intakes
- Air Conditioner
- Overhang, soffits, porch roofs, adjacent walls
- Landscaping, vegetation
- Horizontal or vertical vent termination

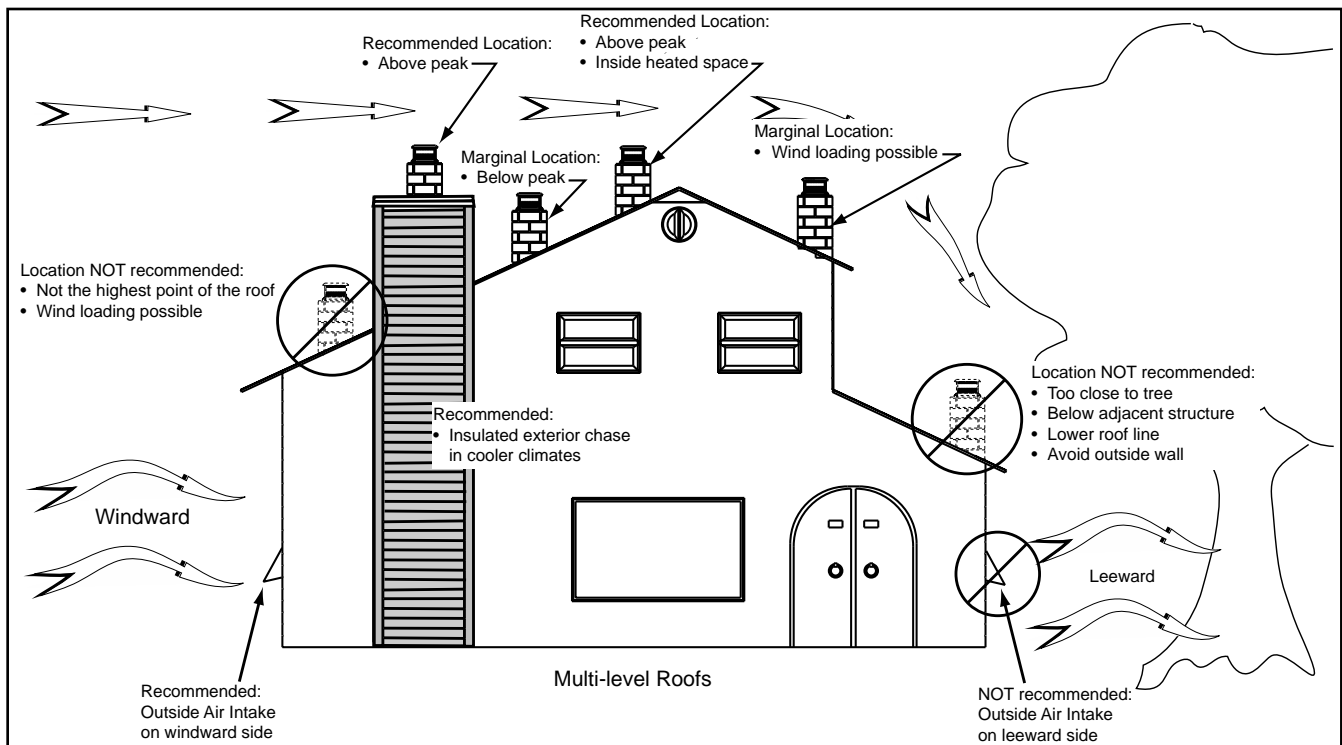
#### 2. Floor Support

The supporting floor under the appliance must be able to handle the weight of the appliance, fuel load and the weight of the chimney.

Ensure that your floor will support these weights prior to installation. Add sufficient additional support to meet this weight requirement prior to installation. The weight of the appliance is 429 lbs.

**WARNING! Risk of Fire** Damaged parts could impair safe operation. Do NOT install damaged, incomplete or substitute components.

**CAUTION!** If burning shelled field corn, you must use approved venting specifically designed for corn to prevent corrosion or degradation. Follow the instructions from the venting manufacturer.



**Figure 5.1**

**B. Thermostat Wall Control Location**

The thermostat wall control’s location will have some affect on the appliance’s operation.

- Maximum wire length from appliance is 100 feet (30.48m) continuous unspliced wire. Recommended 20 gauge wire, solid copper .
- When located close to the appliance, it may require a slightly higher temperature setting to keep the rest of the house comfortable.
- When located in an adjacent room or on a different floor level, you will notice higher temperatures near the appliance.

**CAUTION!** *The wall control is an integral part of the appliance. No other wall control or thermostat can be substituted.*

**C. Tools And Supplies Needed**

<b>Tools and building supplies normally required for installation, unless installing into an existing masonry fireplace:</b>	
Reciprocating Saw	Safety Glasses
Channel Locks	Framing Square
Hammer	Electric Drill & Bits (1/4")
Phillips Screwdriver	1/4" Self-Tapping Screws
Tape Measure	
Plumb Line	<u>May also need:</u>
Level	Vent Support Straps
Framing Material	Venting Paint
Hi-temp Caulking Material	
Gloves	

**D. Inspect Appliance and Components**

**WARNING! Risk of Fire!** *Damaged parts could impair safe operation. Do NOT install damaged, incomplete or substitute components.*

- Open the appliance and remove all the parts and articles packed inside the Component Pack. Inspect all the parts and glass for shipping damage.
- Report to your dealer any parts damaged in shipment.
- All labels have been removed from the glass door.
- Plated surfaces have been wiped clean with a soft cloth, if applicable.
- **Read all the instructions before starting the installation. Follow these instructions carefully during the installation to ensure maximum safety and benefit.**
- **Follow pipe manufacturer instructions for installation and air clearance requirements.**

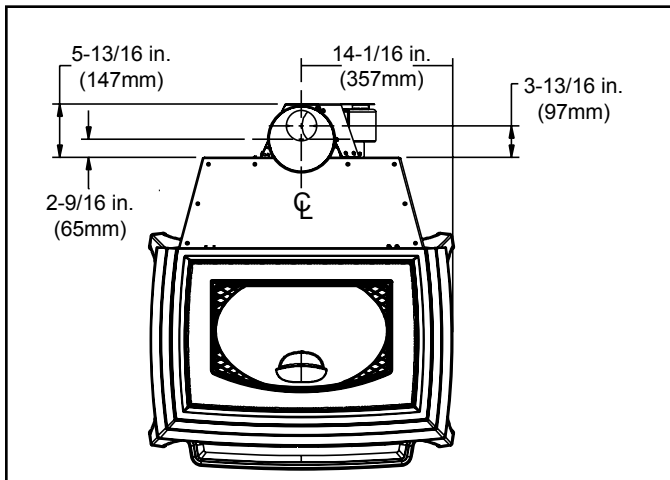
**E. Pre-Use Check List**

1.		Place the appliance in a location near the final installation area and follow the procedures below:
2.		Open the appliance and remove all the parts and articles packed inside the Component Pack.  Inspect all the parts and glass for shipping damage. Contact your dealer if any irregularities are noticed.  Remove rubber band from ash pan installed for shipping purposes only.
3.		All safety warnings have been read and followed.
4.		This Owner’s Manual has been read.
5.		Floor protection requirements have been met.
6.		Venting is properly installed.
7.		The proper clearances from the appliance and chimney to combustible materials have been met.
8.		The masonry chimney is inspected by a professional and is clean, or the factory built metal chimney is installed according to the manufacturer’s instructions and clearances.
9.		The chimney meets the required minimum height.
10.		All labels have been removed from the glass door.
11.		Plated surfaces have been wiped clean, if applicable.
12.		Wall Control Thermostat has been installed.
13.		A power outlet is available nearby.
14.		A good quality surge protectory is highly recommended to protect the electronics.

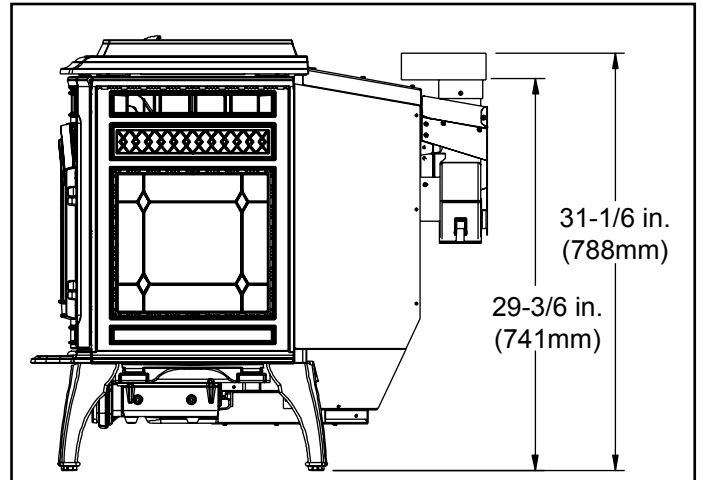
	<p><b>WARNING</b></p>
<p>Hearth &amp; Home Technologies disclaims any responsibility for, and the warranty will be voided by, the following actions:</p> <ul style="list-style-type: none"> <li>• Installation and use of any damaged appliance.</li> <li>• Modification of the appliance.</li> <li>• Installation other than as instructed by Hearth &amp; Home Technologies.</li> <li>• Installation and/or use of any component part not approved by Hearth &amp; Home Technologies.</li> <li>• Operating appliance without fully assembling all components.</li> <li>• Operating appliance without legs attached (if supplied with unit).</li> <li>• Do NOT Overfire</li> </ul>	
<p><b>Or any such action that may cause a fire hazard.</b></p>	

# 3 Dimensions and Clearances

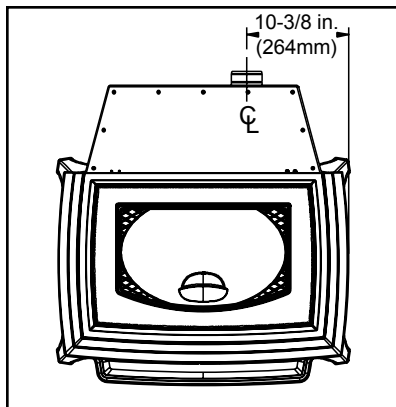
## A. Appliance Dimensions



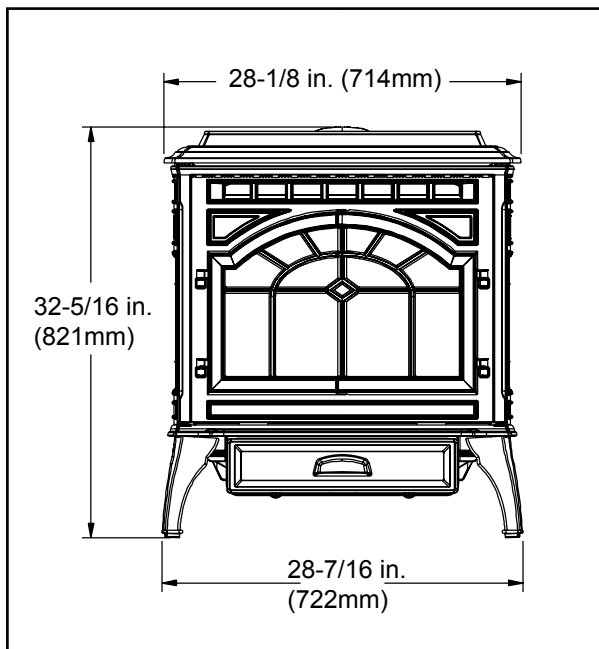
**Figure 7.1 - Top View with Top Vent Adapter and 3 to 6 in (76-152mm) Adapter**



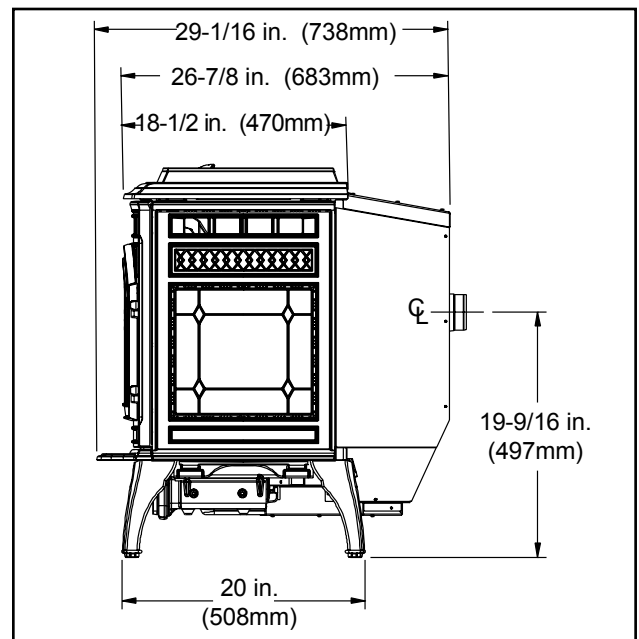
**Figure 7.2 - Side View with Top Vent Adapter and 3 to 6 in (76-152mm) Offset Adapter.**



**Figure 7.3 - Top View**

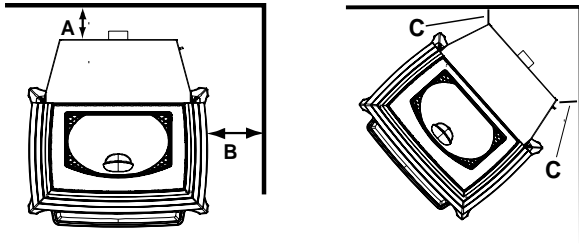


**Figure 7.4 - Front View**



**Figure 7.5 - Side View**

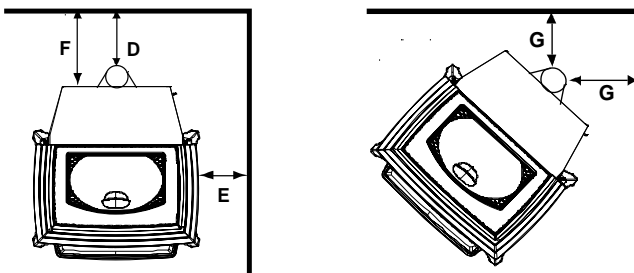
**B. Clearances to Combustibles (UL and ULC)**



Straight Back Against Wall		Inches	Millimeters
<b>A</b>	Back Wall to Appliance	2	51
<b>B</b>	Side Wall to Appliance	6	152

Corner Installation		Inches	Millimeters
<b>C</b>	Walls to Appliance	2	51

**Installations with:  
3 to 3 inch Top Vent Adapter and  
3 to 6 inch Offset Adapter Kit**



Vertical Installation		Inches	Millimeters
<b>D</b>	Back Wall to Flue Pipe	3	76
<b>E</b>	Side Wall to Appliance	6	152
<b>F</b>	Back Wall to Appliance	8	203

Corner Installation		Inches	Millimeters
<b>G</b>	Side Wall to Flue Pipe	3	76

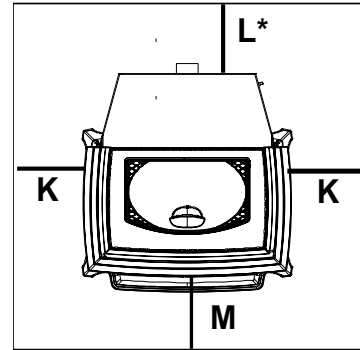
Alcove Installation		Inches	Millimeters
Minimum Alcove Height		43	1092
Minimum Alcove Side Wall		6	152
Minimum Alcove Width		40	1016
Maximum Alcove Depth		36	914

**NOTE:**

- Illustrations reflect typical installations and are FOR DESIGN PURPOSES ONLY.
- Illustrations/diagrams are not drawn to scale.
- Actual installation may vary due to individual design preference.

**C. Hearth Pad Requirements (UL and ULC)**

Use a non-combustible floor protector, extending beneath appliance and to the front, sides and rear as indicated. Measure front distance "M" from the surface of the glass door.

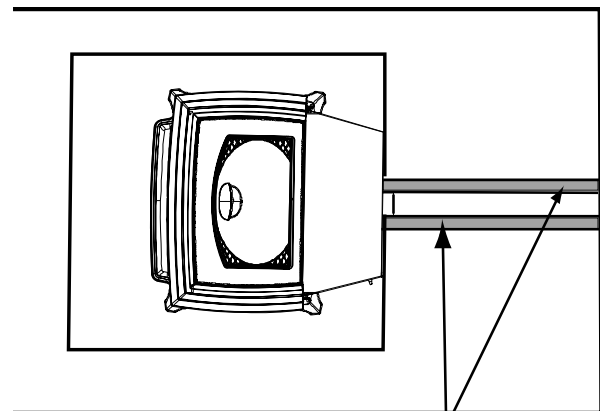


Hearth Pad Requirements		Inches	Millimeters
<b>K</b>	Sides	2	51
<b>L*</b>	Back	2	51
<b>M</b>	Front	6	152

**\*L Exception for Horizontal Installations:**

**USA INSTALLATIONS:** A non-combustible floor protection is recommended extending beneath the flue pipe when installed with horizontal venting or under the Top Vent Adapter with vertical installation.

**CANADA INSTALLATIONS:** A non-combustible floor protection extending beneath the flue pipe is **required** with horizontal venting or under the Top Vent Adapter with vertical installation.



Must extend 2 inches (51mm) beyond each side of pipe (shaded area)

**WARNING**

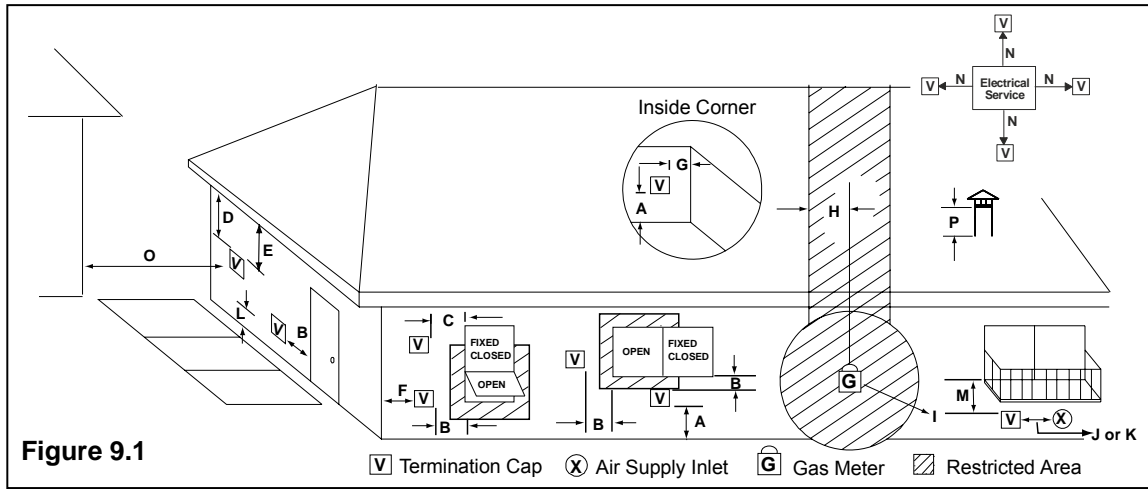


Fire Risk.  
Comply with all minimum clearances to combustibles as specified.  
Failure to comply may cause house fire.



# 4 Vent Information

## A. Venting Termination Minimum Requirements



**Figure 9.1**

V Termination Cap X Air Supply Inlet G Gas Meter Restricted Area

All minimum clearances are listed with an Outside Air Kit (OAK) installed, unless otherwise noted in table below.

<b>A</b>	12 in.	Above Finish Grade (the grade surface must be a non-combustible material)
<b>B</b>	12 in. 48 in. no OAK	Open door or window: below or to the side
<b>B</b>	12 in.	Open door or window: above
<b>C</b>	6 in.	Permanently closed window: above, below or to the side
<b>D</b>	18 in. 36 in. no OAK	Vertical clearance to a ventilated soffit located above the terminal within a horizontal distance of 2 ft from the center-line of the terminal
<b>E</b>	12 in.	Clearance to unventilated soffit
<b>F</b>	12 in.	Clearance to outside corner
<b>G</b>	12 in.	Clearance to inside corner
<b>H</b>	36 in.	Above gas meter/regulator measured from horizontal center-line of regulator
<b>I</b>	36 in. USA 72 in. Canada	Clearance to service regulator vent outlet
<b>J</b>	12 in. 48 in. no OAK	Clearance to non-mechanical air supply inlet to the building or the combustions air inlet to any other appliance
<b>K</b>	10 ft horizontal 3 ft vertical	Clearance to mechanical air supply
<b>L</b>	7 ft.	Above paved sidewalk, paved driveway located on <b>public</b> property
<b>M</b>	12 in.	Under an open veranda, porch, deck or balcony
<b>N</b>	See Note below*	Electric service: above, below or to the side (location must not obstruct or interfere with access)
<b>O</b>	24 in.	Adjacent building, fences and protruding parts of the structure
<b>P</b>	12 in.	Clearance above roof line for vertical terminations

24 in.	Above grass, top of plants, wood or any other combustible
12 in. 36 in. no OAK	Clearance from any forced air intake of other appliance
12 in.	Clearance horizontally from combustible wall
15 in.	Vented directly through a wall, minimum length of horizontal pipe
6 in. horizontal 12 in. vertical	Minimum horizontal or vertical terminations must protrude from wall

**NOTICE:**

**Do NOT Terminate Vent:**

- In any location that will allow flue gases or soot from entering or staining the building
- In any location which could create a nuisance or hazard
- In any enclosed or semi-enclosed area such as a carport, garage, attic, crawl space, under a sun deck or porch, narrow walkway
- Closely fenced area, or any location that can build up a concentration of fumes such as a stairwell, covered breezeway, etc.

**NOTICE:**

**Termination must exhaust above air inlet elevation.**

- It is recommended that at least 60 inches (1.52m) of vertical pipe be installed when appliance is vented directly through a wall. This will create a natural draft, which will help prevent the possibility of smoke or odor venting into the home during a power outage.
- It will also keep exhaust from causing a nuisance or hazard by exposing people or shrubs to high temperatures.
- The safest and preferred venting method is to extend the vent vertically through the roof or above the roof.

\*NOTE: Consult local building, fire officials or authorities having jurisdiction. Local codes or regulations may require different clearances.

## B. Avoiding Smoke and Odors

### Negative Pressure, Shut-Down and Electrical Power Failure

To reduce the probability of back-drafting or burn-back in the pellet appliance during power failure or shut down conditions, it must be able to draft naturally without exhaust blower operation.

Negative pressure in the house will resist this natural draft if not accounted for in the pellet appliance installation.

Heat rises in the house and leaks out at upper levels. This air must be replaced with cold air from outdoors which flows into lower levels of the house.

Vents and chimneys into basements and lower levels of the house can become the conduit for air supply and reverse under these conditions.

### Outside Air

An outside air kit is recommended in all installations. The Outside Air Kit must be ordered separately.

Per national building codes, consideration must be given to combustion air supply to all combustion appliances. Failure to supply adequate combustion air for all appliance demands may lead to backdrafting of those and other appliances.

When the appliance is roof vented (strongly recommended):

The air intake is best located on the exterior wall oriented towards the prevailing wind direction during the heating season.

When the appliance is side-wall vented:

The air intake is best located on the same exterior wall as the exhaust vent outlet and located lower on the wall than the exhaust vent outlet.

The outside air supply kit can supply most of the demands of the pellet appliance, but consideration must be given to the total house demand.

House demand may consume the air needed for the appliance. It may be necessary to add additional ventilation to the space in which the pellet appliance is located.

Consult with your local HVAC professional to determine the ventilation demands for your house.

### Vent Configurations

To reduce probability of reverse drafting during shut-down conditions Hearth & Home Technologies strongly recommends:

- Installing the pellet vent with a minimum vertical run of 5 feet (1.52m). Preferably terminating above the roof line.
- Installing the outside air kit at least 4 feet (1.22m) below the vent termination.

To prevent soot damage to exterior walls of the house and to prevent re-entry of soot or ash into the house:

- Maintain specified clearances to windows, doors and air inlets, including air conditioners.
- Vents should not be placed below ventilated soffits. Run the vent above the roof.
- Avoid venting into alcove locations.
- Vents should not terminate under overhangs, decks or onto covered porches.
- Maintain minimum clearance of 12 inches (305mm) from the vent termination to the exterior wall. If you see deposits developing on the wall, you may need to extend this distance to accommodate your installation conditions.



### CAUTION

- DO NOT CONNECT THIS UNIT TO A CHIMNEY FLUE SERVICING ANOTHER APPLIANCE.
- DO NOT CONNECT TO ANY AIR DISTRIBUTION DUCT OR SYSTEM.

### Optional Battery Back-Up

Hearth & Home Technologies supplies an optional battery back-up system that operates the appliance during power failure conditions to prevent smoking. In shutdown mode, the battery back-up will not prevent smoking. **See Section 8 for details.**

Hearth & Home Technologies assumes no responsibility for, nor does the warranty extend to, smoke damage caused by reverse drafting of pellet appliances under shut down or power failure conditions.

### C. Negative Pressure

**WARNING! Risk of Asphyxiation!** Negative pressure can cause spillage of combustion fumes and soot.

Negative pressure results from the imbalance of air available for the appliance to operate properly. It can be strongest in lower levels of the house.

Causes include:

- Exhaust fans (kitchen, bath, etc.)
- Range hoods
- Combustion air requirements for furnaces, water heaters and other combustion appliances
- Clothes dryers
- Location of return-air vents to furnace or air conditioning
- Imbalances of the HVAC air handling system
- Upper level air leaks such as:
  - Recessed lighting
  - Attic hatch
  - Duct leaks

To minimize the effects of negative air pressure:

- Install the outside air kit with the intake facing prevailing winds during the heating season
- Ensure adequate outdoor air for all combustion appliances and exhaust equipment
- Ensure furnace and air conditioning return vents are not located in the immediate vicinity of the appliance
- Avoid installing the appliance near doors, walkways or small isolated spaces
- Recessed lighting should be a “sealed can” design
- Attic hatches weather stripped or sealed
- Attic mounted duct work and air handler joints and seams taped or sealed

### D. Draft

Draft is the pressure difference needed to vent an appliance successfully. When an appliance is drafting successfully, all combustion byproducts are exiting the home through the chimney.

Install through the warm airspace enclosed by the building envelope. This helps to produce more draft, especially during lighting and die-down of the fire.

Considerations for successful draft include:

- Preventing negative pressure
- Location of appliance and chimney

**NOTICE:** *Hearth & Home Technologies assumes no responsibility for the improper performance of the chimney system caused by:*

- *Inadequate draft due to environmental conditions*
- *Downdrafts*
- *Tight sealing construction of the structure*
- *Mechanical exhausting devices*

**E. Chimney and Exhaust Connection**

1. **Chimney & Connector:** Use 3 or 4 inch (76-102mm) diameter type "L" or "PL" venting system. It can be vented vertically or horizontally.
2. **Mobile Home:** Approved for all Listed pellet vent. If using the 3 inch (76mm) vertical Top Vent Adapter Kit or the 3 to 6 inch (76-152mm) Top Vent Offset Adapter, use Listed double wall flue connector. A Quadra-Fire Outside Air Kit must be used with manufactured home installations.
3. **Residential:** The 3 inch (76mm) vertical Top Vent Adapter Kit and the 3 to 6 inch (76-152mm) Top Vent Offset Adapter are tested to use 24 gauge single wall flue connector or Listed double wall flue connector to Class A Listed metal chimneys, or masonry chimneys meeting International Residential Code standards for solid fuel appliances.
4. **INSTALL VENT AT CLEARANCES SPECIFIED BY THE VENT MANUFACTURER.**
5. Secure exhaust venting system to the appliance with at least 3 screws. Also secure all connector pipe joints with at least 3 screws through each joint.
6. **DO NOT INSTALL A FLUE DAMPER IN THE EXHAUST VENTING SYSTEM OF THIS UNIT.**
7. **DO NOT CONNECT THIS UNIT TO A CHIMNEY FLUE SERVING ANOTHER APPLIANCE.**

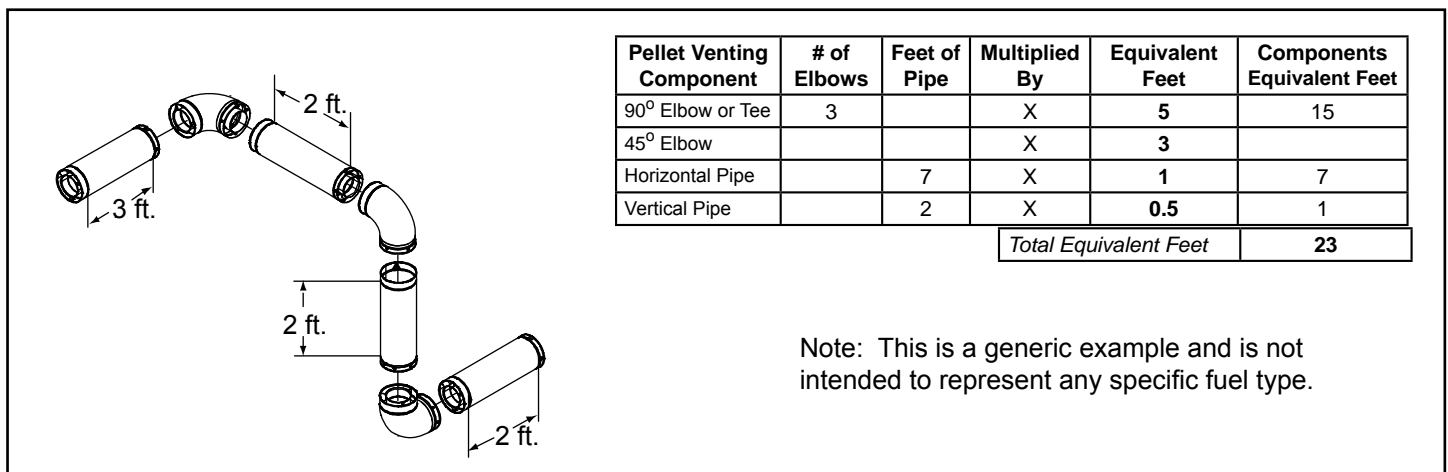
**NOTE: All pipe must be welded seam pipe whenever possible. Seal pipe joints with high temperature silicone (500°F [260°C] minimum rated only).**

**NOTE: If burning shelled field corn, you must use approved venting specifically designed for corn. Follow the instructions from the venting manufacturer.**

**F. Equivalent Feet of Pipe**

The table below can help you calculate the equivalent feet of pipe which is a method used to determine pellet vent size. **Figure 12.1.**

**Example of 3 Elbow-Rear Vent Termination Calculation**




**Figure 12.1**

**WARNING! RISK OF FIRE!**

- Only LISTED venting components may be used.
- NO OTHER vent components may be used.
- Substitute or damaged vent components may impair safe operation.

**⚠ WARNING**



Vent surfaces get HOT, can cause burns if touched. Non-combustible shielding or guards may be required.

**WARNING! RISK OF INJURY OR PROPERTY DAMAGE!**

- Improper installation, adjustment, alteration, service or maintenance can cause injury or property damage.
- Refer to the owner's information manual provided with this appliance.
- For assistance or additional information consult a qualified installer, service agency or your dealer.

**G. Pipe Selection Chart**

The chart will help you in determining proper venting size according to the equivalent feet of pipe calculated previously and the altitude above sea level of this installation.

**Figure 13.1.**

- a. Locate the calculated equivalent feet of pipe on the vertical left side of the chart.
- b. Move to the right horizontally on the chart until you reach your altitude above sea level.
- c. If you fall below the diagonal line, 3 or 4 inch (76 to 102mm) pipe may be used.
- d. If it is anywhere above the diagonal line, a 4 inch (102mm) diameter pipe is required.

**NOTICE:**

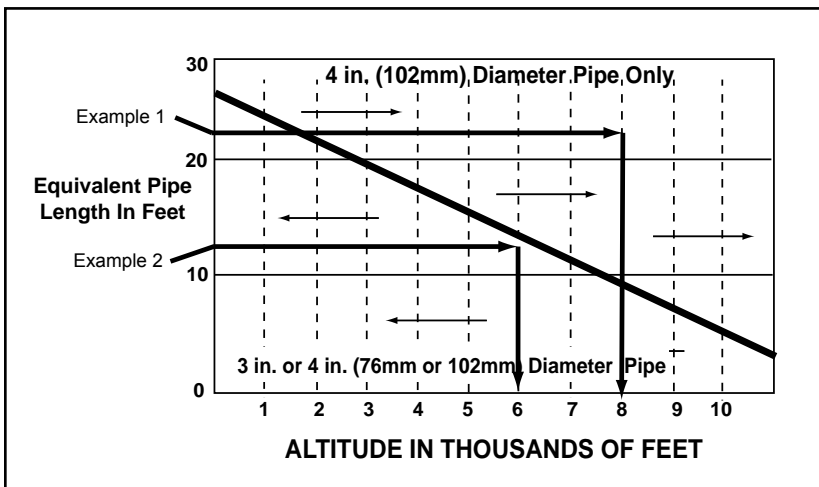
- A 90° elbow is 5 times as restrictive to the flow of exhaust gases under positive pressure as 1 foot (305mm) of horizontal pipe.
- A foot of horizontal pipe is twice as restrictive as a foot of vertical pipe.

**WARNING! RISK OF FIRE!**

Do NOT pack insulation or other combustibles between firestops.

- ALWAYS maintain specified clearances around venting and firestop systems.
- Install firestops as specified.

Failure to keep insulation or other material away from vent pipe may cause fire.



**Figure 13.1**

**Example 1:** If the equivalent length of pipe is 23 feet (.58m) with altitude of 8,000 feet (203m) you must use 4 inch (102mm) diameter type “L” or “PL” vent.

**Example 2:** If the equivalent length of pipe is 12 feet (.30m) with altitude of 6,000 feet (152m) you may use 3 or 4 inch (76 to 102mm) diameter type “L” or “PL” vent.

# 5 Venting Systems

## A. Alcove

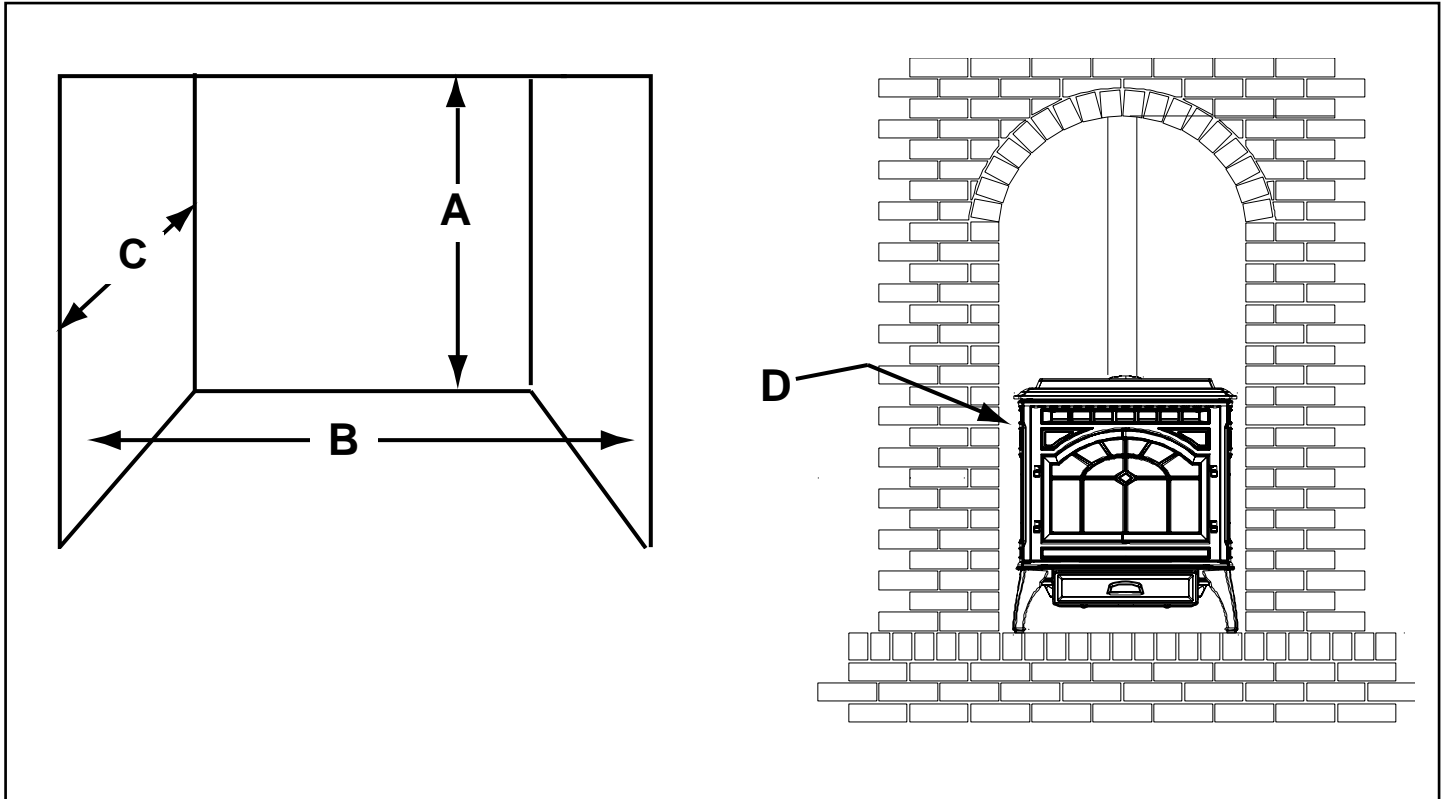


Figure 14.1

		Minimum*		Maximum	
		Inches	Millimeters	Inches	Millimeters
<b>A</b>	Height	43	1092	n/a	n/a
<b>B</b>	Width	40	1016	n/a	n/a
<b>C</b>	Depth	n/a	n/a	36	914
<b>D</b>	To Side Wall	6	152	n/a	n/a

\*All minimums listed are to a combustible surface.

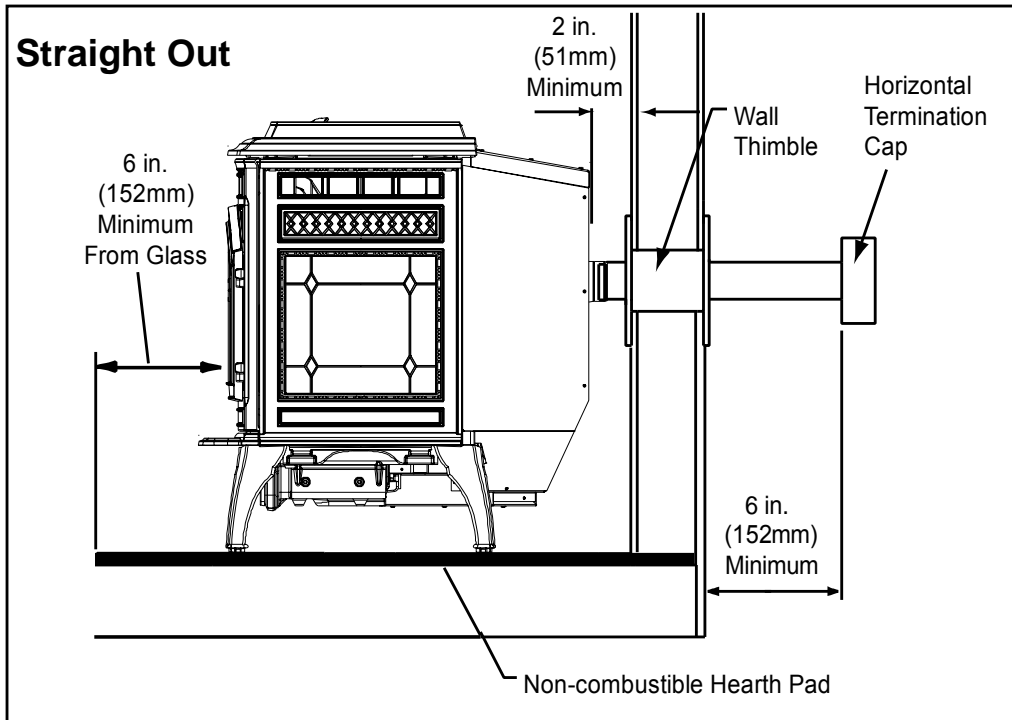
**NOTE:**

- Illustrations reflect typical installations and are FOR DESIGN PURPOSES ONLY.
- Illustrations/diagrams are not drawn to scale.
- Actual installation may vary due to individual design preference.

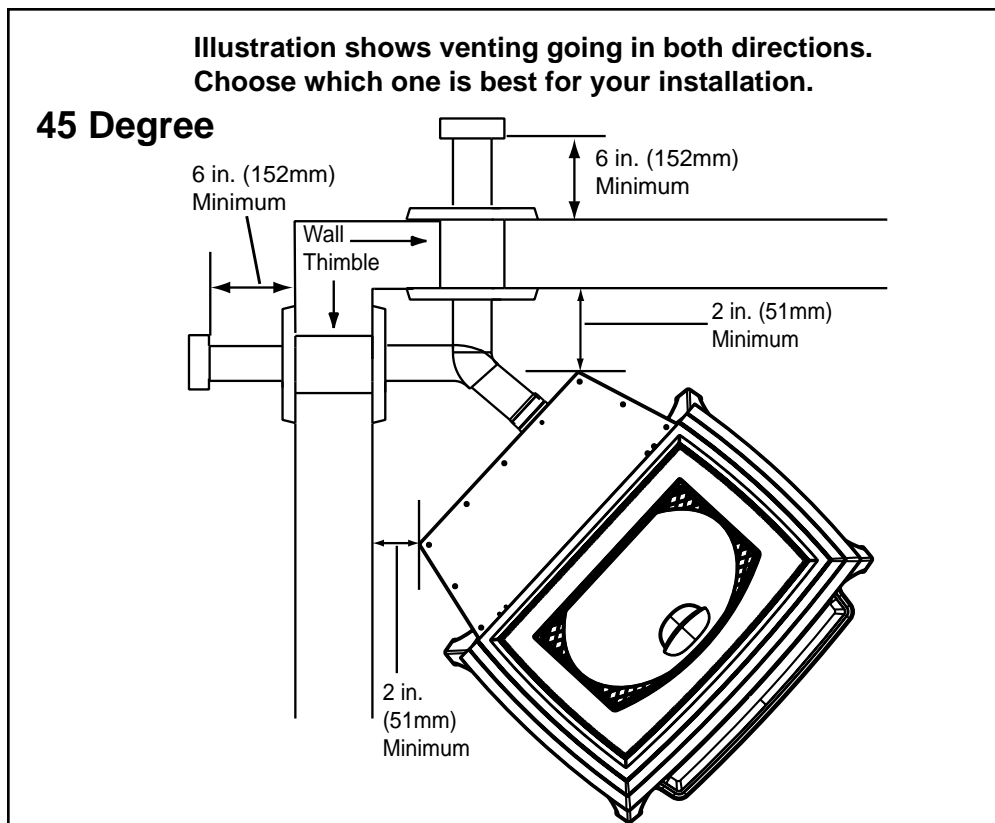
**B. Through The Wall**

Horizontal termination cap must be a minimum of 6 inches. (152mm) from the wall. Approved for mobile home installations. Must use 3 or 4 inch (76-102mm) "L" or "PL" Listed pellet venting or Listed double wall pipe and a Quadra-Fire Outside Air Kit in mobile homes.

**NOTE:**  
In Canada, where passage through a wall or partition of combustible construction is desired, the installation shall conform to CAN/CSA-B365

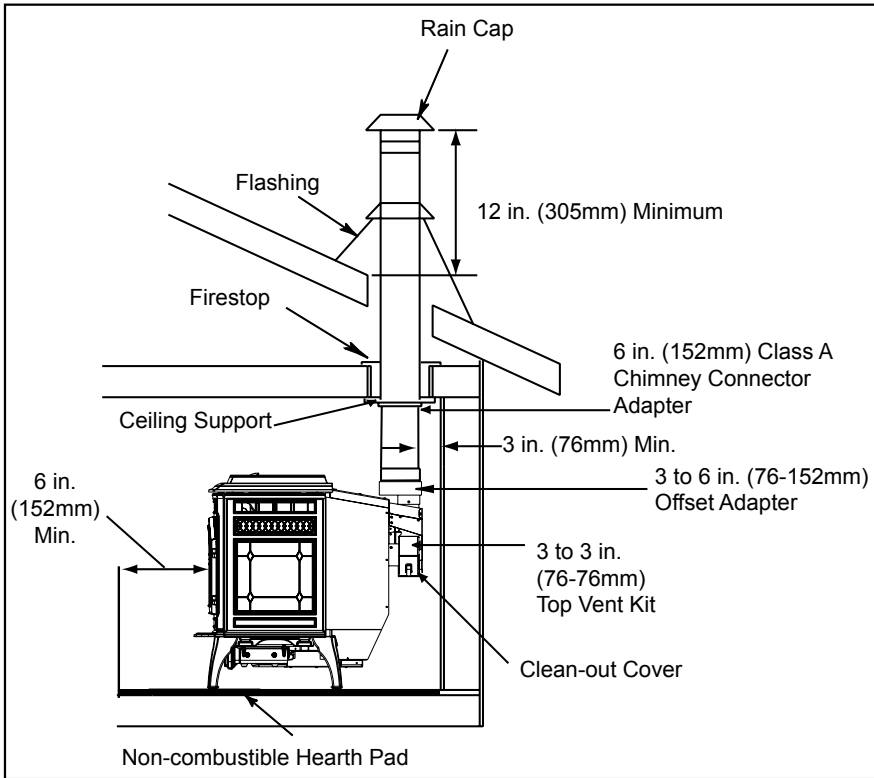


**Figure 15.1**



**Figure 15.2**

**C. Vertical into Existing Class A Chimney**



We recommend a minimum of 60 inches (1524mm) vertical, however above the eave is preferred.

All three installations are approved for mobile home installations. Must use 3 or 4 inch (76 to 102mm) "L" or "PL" Listed pellet venting or Listed double wall pipe and Quadra-Fire Outside Air Kit in mobile homes. Single wall pipe is approved for residential installations only.

\*NOTE: Clearance to combustibles are for standard pellet pipe. If pellet pipe manufacturer allows reduced clearances to their pipe, reduced clearances are allowed.

Figure 16.1

**D. Through The Wall & Vertical - Exterior**

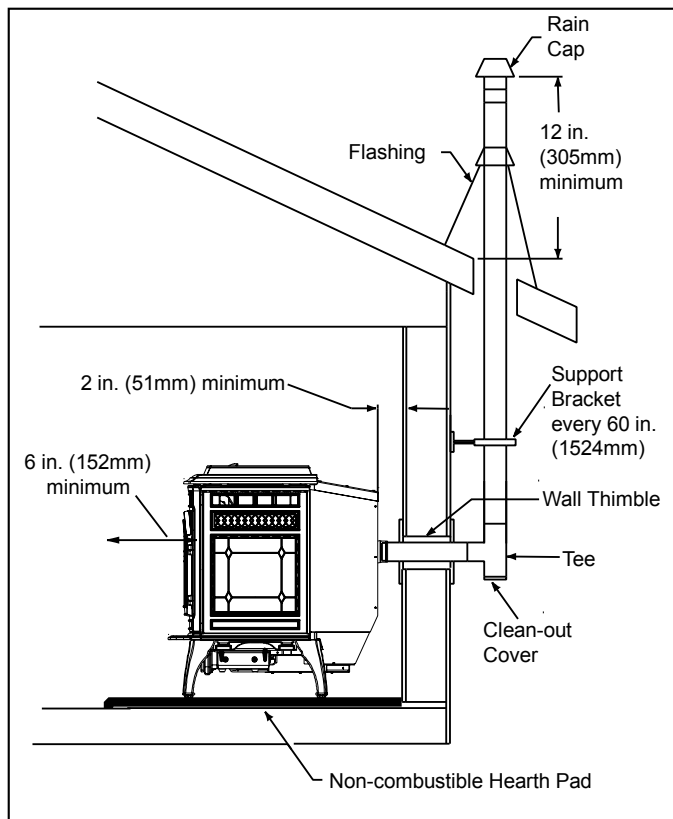


Figure 16.2

**E. Vertical - Interior - Typical Installation**

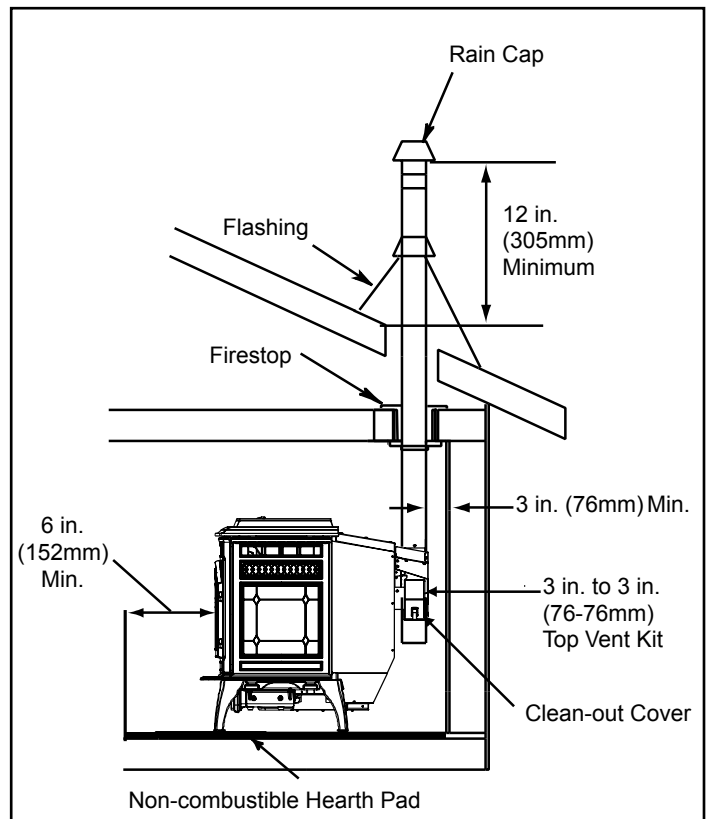




Figure 16.3





**WARNING**

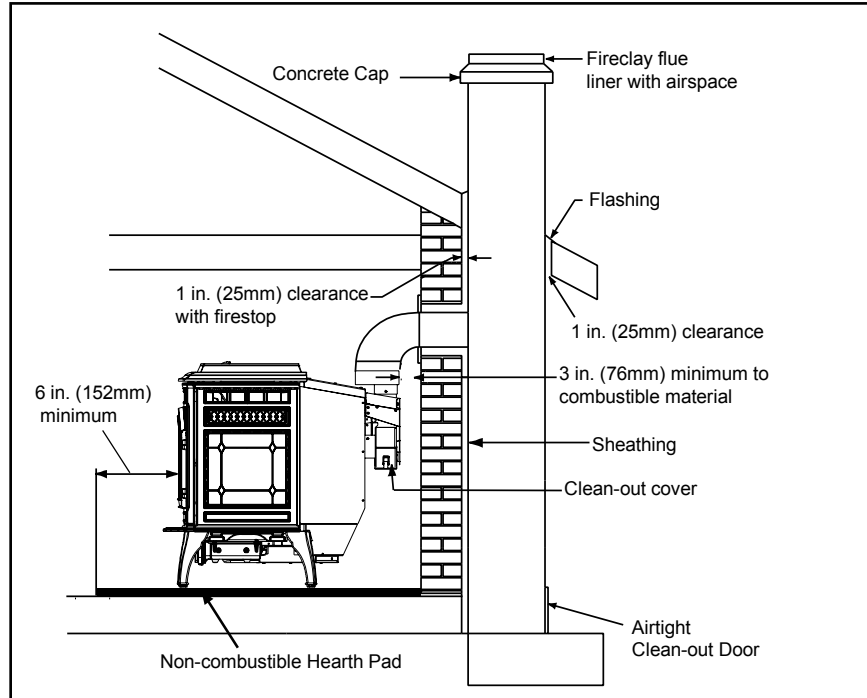


**Fire Risk.**

Inspection of Chimney:

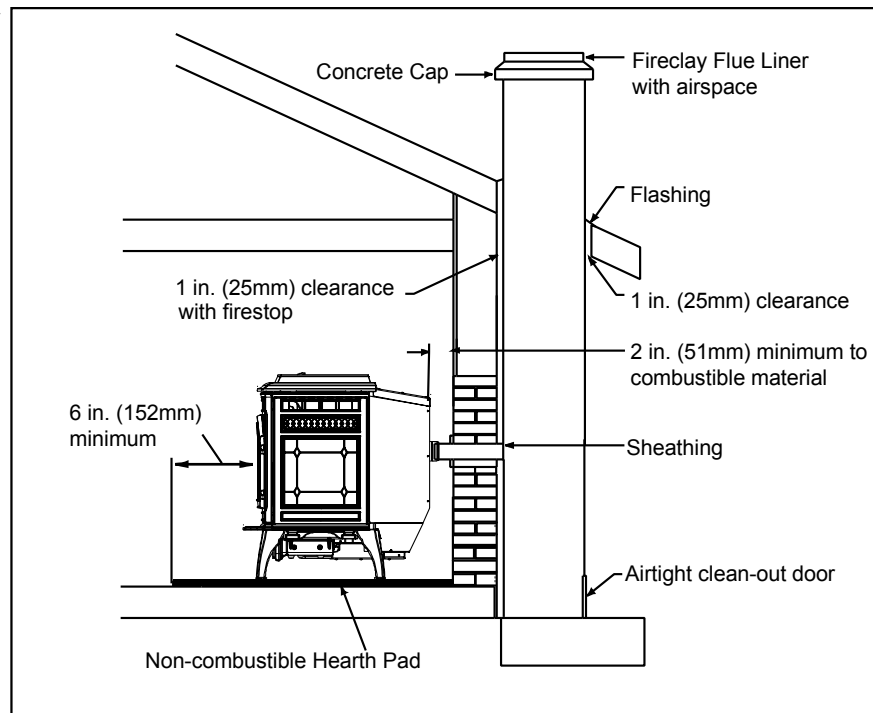
- Masonry chimney must be in good condition.
- Meets minimum standard of NFPA 211
- Factory-built chimney must be a minimum 6 inch (152mm) UL103 HT.

**F. Masonry**



**Figure 17.1**

**G. Alternate Masonry**



**Figure 17.2**

# 6 Mobile Home Installation

## You must use a Quadra-Fire Outside Air Kit for installation in a mobile home.

1. An outside air inlet must be provided for the combustion air and must remain clear of leaves, debris, ice and/or snow. It must be unrestricted while the appliance is in use to prevent room air starvation which causes smoke spillage. Smoke spillage can also set off smoke alarms.
2. The combustion air duct system must be made of metal. It must permit zero clearance to combustible construction and prevent material from dropping into the inlet or into the area beneath the dwelling and contain a rodent screen.
3. The appliance must be secured to the mobile home structure by bolting it to the floor (using lag bolts). Use the same holes that secured the appliance to the shipping pallet.
4. The appliance must be grounded with #8 solid copper grounding wire or equivalent, terminated at each end with an NEC approved grounding device.
5. Refer to Clearances to Combustibles and floor protection requirements on **page 8** for listings to combustibles and appropriate chimney systems.
6. Use silicone to create an effective vapor barrier at the location where the chimney or other component penetrates to the exterior of the structure.
7. Follow the chimney manufacturer's instructions when installing the vent system for use in a mobile home.
8. Installation shall be in accordance with the Manufacturers Home & Safety Standard (HUD) CFR 3280, Part 24.

### CAUTION

THE STRUCTURAL INTEGRITY OF THE MOBILE HOME FLOOR, WALL AND CEILING/ROOF MUST BE MAINTAINED

Do NOT cut through:

- Floor joist, wall, studs or ceiling trusses.
- Any supporting material that would affect the structural integrity.

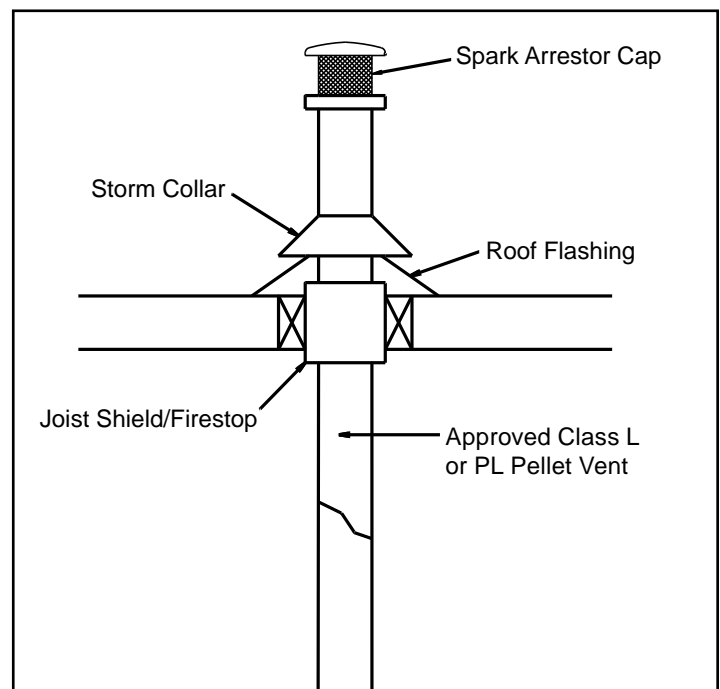


Figure 18.1



### WARNING

NEVER INSTALL IN A SLEEPING ROOM.

### CAUTION

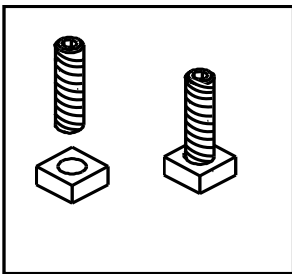
Never draw outside combustion air from:

- Wall, floor or ceiling cavity
- Enclosed space such as an attic or garage

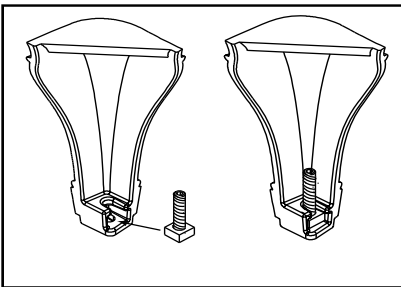
# 7 Appliance Set-Up

## A. Leg Leveling System

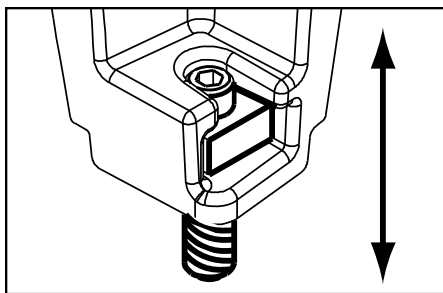
1. Thread Allen bolts through nuts until flush. **Figure 19.1.** The Allen bolts and nuts are included in the component pack inside the appliance firebox.
2. Slide assembled nuts and bolts into slots on legs with the nuts on the bottom. **Figure 19.2.** Use a 5/32 in. (3.96mm) Allen wrench to adjust legs up and down to desired level. **Figure 19.3.**



**Figure 19.1**



**Figure 19.2**



**Figure 19.3 - Bolt fully extended**

## B. Outside Air Kit Instructions

### CAUTION

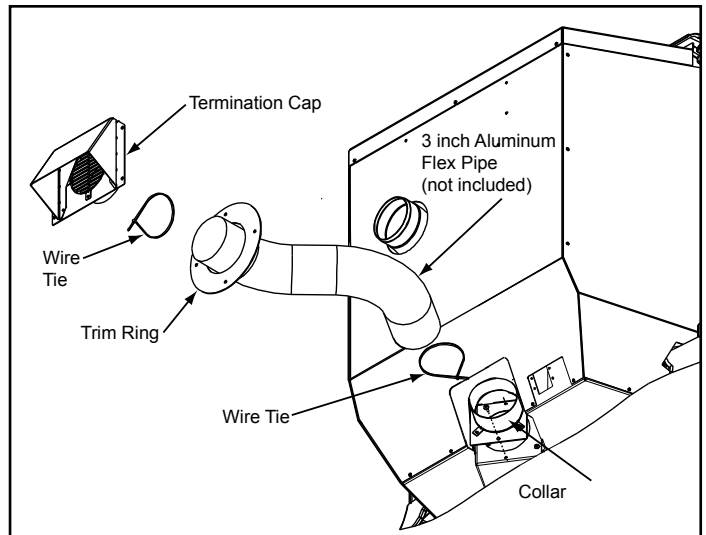
- Never draw outside combustion air from:
- Wall, floor or ceiling cavity
  - Enclosed space such as an attic or garage

**Included in Kit:** 2 wire ties, 1 collar assembly, 1 termination cap assembly, 1 trim ring, fasteners.

**NOTE:** 3 INCH ALUMINUM FLEX PIPE NOT INCLUDED.

**Tools Needed:** Phillips head screw driver; wire cutters; hole saw or jig saw.

1. Measure distance from floor to air vent opening in appliance and mark location on wall.  
Use saw to cut opening in wall. Cut a 3-1/2 to 4 inch (89-102mm) opening on inside wall and a 4 to 4-1/2 inch (102-114mm) opening on outside of house.
2. Use wire tie to secure flex pipe to collar assembly.
3. Slide trim ring over flex pipe and run pipe through wall.
4. Attach flex pipe (not supplied) to outside termination cap with second wire tie.
5. Secure termination cap to outside surface.
6. Secure trim ring to interior wall.



**Figure 19.4**

### C. Top Vent Adapter Installation

**3 to 3 inch (76-76mm) Top Vent Adapter**  
**3 to 6 inch (76-152mm) Top Vent Offset Adapter**

#### Installing the Top Vent Adapter

1. Put a layer of high temperature silicone on the 3 inch (76mm) exhaust outlet. **Do not put silicone inside of pipe. Figure 20.1.**
2. Slide the top vent adapter onto the rear exhaust outlet and adjust the assembly to a vertical position until the top of the flue outlet is centered and is in a level position. **Figure 20.1.**
3. Align slot on left of adapter with hole in the back of the unit and secure with screw. You may drill out the hole using #26 drill bit provided but only if needed. **Figure 20.2.**
4. Install the 5 mounting screws, 3 on the left and 2 on the right.
5. Drill 2 holes with #26 drill bit through the rear exhaust outlet using the 2 holes already in the short horizontal pipe in the top vent adapter as a guide. Install the screws. **Figure 20.2.**
6. Install the vent pipe into the top vent adapter (be sure to silicone all joints). To use an existing 6 inch (152mm) vent system, install the 3 to 6 in (76-152mm) offset adapter before installing vent pipe.
7. To clean top vent adapter, open clean-out cover and remove any debris build-up. **Figure 20.2.**

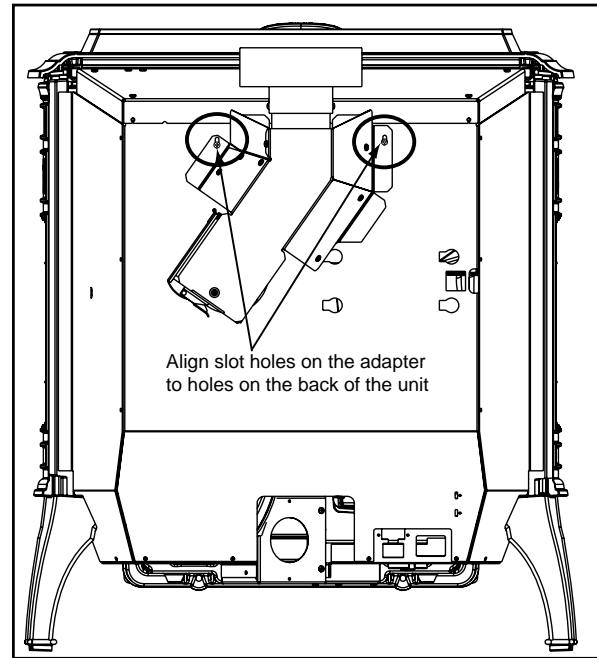


Figure 20.2

### D. Rear Vent and Rear Vent to Top Vent Adapter Installation

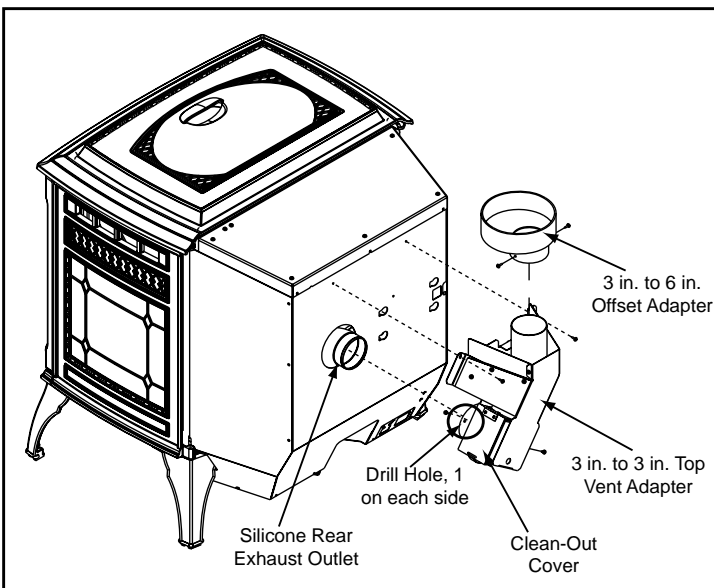


Figure 20.1

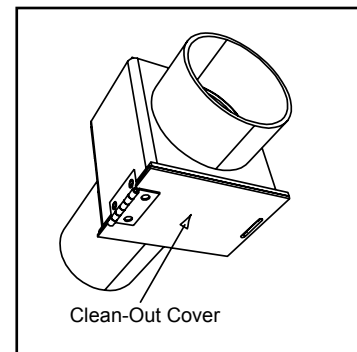


Figure 20.3 - Rear Vent Adapter

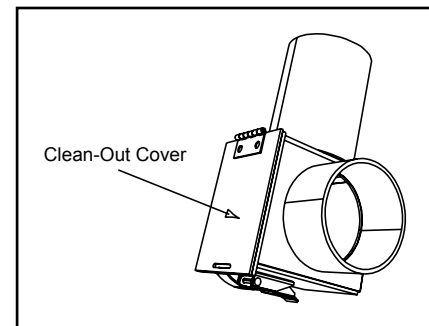


Figure 20.4 - Rear to Top Vent Adapter - 90°

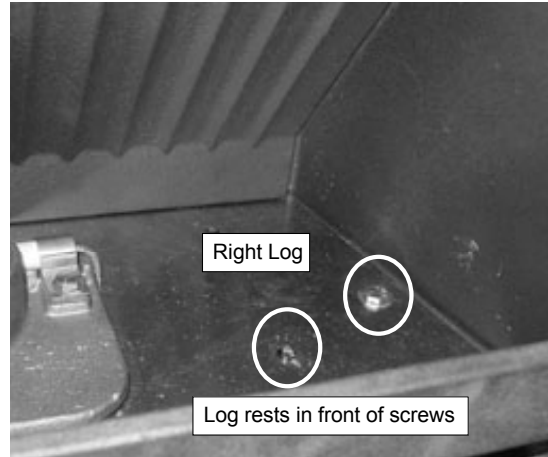
1. Put a layer of high temperature silicone on the 3 inch (76mm) exhaust outlet. **Do not put silicone inside of pipe. Figure 20.1.**
2. Slide the adapter onto the rear exhaust outlet and adjust the assembly to the appropriate position.
3. Install the vent pipe into the adapter (be sure to silicone all joints)

**E. Optional Log Set Placement Instructions**

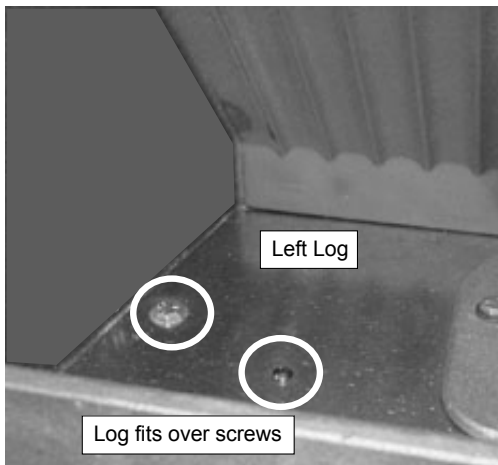
**2 PIECE LOG SET INSTALLATION**

1. Place the left log as shown. There are 2 indentations in the bottom of the log to fit over the screw heads in the firebox. **Figures 21.1 and 21.2.**
2. Place the right log in front of the 2 screw heads in the firebox. **Figures 21.3 & 21.4.**

<b>CAUTION</b>
Logs are FRAGILE. Use extreme care when handling or cleaning logs.



**Figure 21.3**



**Figure 21.1**



**Figure 21.4**



**Figure 21.2**

<p><b>NOTICE:</b> Due to the abrasive nature of a pellet appliance fire, the logs are not covered under warranty. Any placement variation other than shown here can cause excessive heat and shall void the appliance warranty.</p>
---

**F. Wall Control Thermostat Installation**

1. When mounting the wall control thermostat on the wall, be sure to follow your thermostat wall control's installation instructions carefully.

**NOTE:** The wall control thermostat should be mounted on an inside wall and not in direct line with the appliance convection air.

**NOTE:** If the wall control thermostat is located too close to the appliance, you may need to set the temperature setting slightly higher to maintain the desired temperature in your home.

2. There is a 5 screw terminal block located on the back lower left corner of the appliance directly above the power cord inlet.

The center 3 screws are for the wall control thermostat wires and the 2 outer screws are mounting screw and should not have wires attached to them.

The thermostat wires are color coded. The green wire is on the left, the white in the middle and the red on the right.

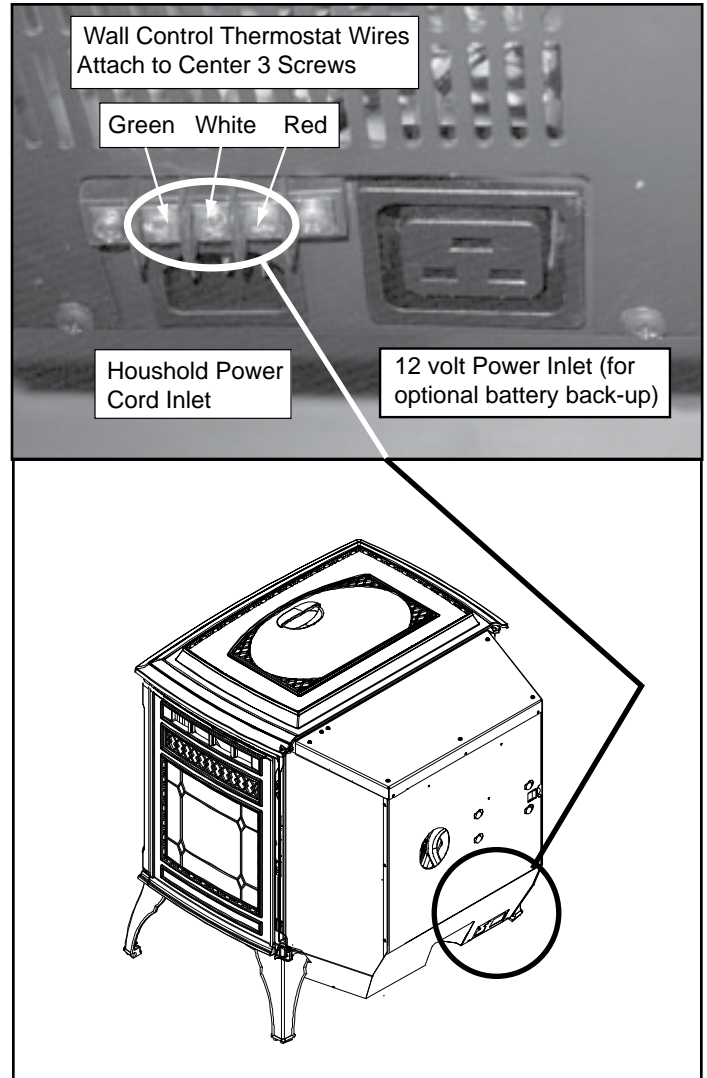


Figure 22.2

	<b>CAUTION</b>
	<p>Shock hazard.</p> <ul style="list-style-type: none"> <li>• Do NOT remove grounding prong from plug.</li> <li>• Plug directly into properly grounded 3 prong receptacle.</li> <li>• Route cord away from appliance.</li> <li>• Do NOT route cord under or in front of appliance.</li> </ul>

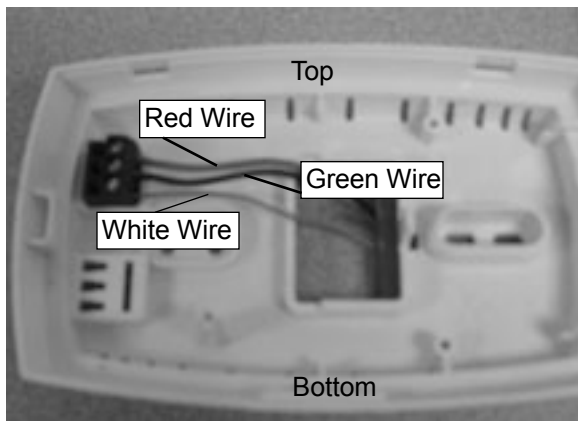





Figure 22.1 - Back Side of Wall Control with Cover Off

# 8 Operating Instructions

	 <b>WARNING</b>
	<p>Fire Risk.</p> <ul style="list-style-type: none"> <li>• Do not operate appliance before reading and understanding operating instructions.</li> <li>• Failure to operate appliance properly may cause a house fire.</li> </ul>

## A. Fire Safety

To provide reasonable fire safety, the following should be given serious consideration:

- Install at least one smoke detector and CO monitor on each floor of your home.
- Locate detectors away from the heating appliance and close to the sleeping areas.
- Follow the detector's manufacturer's placement and installation instructions and maintain regularly.
- Conveniently locate a Class A fire extinguisher to contend with small fires.
- In the event of a hopper fire:
  - Evacuate the house immediately.
  - Notify fire department.

## B. Combustible/Non-Combustible Materials

- **Combustible Material**  
Material made of or surfaced with wood, compressed paper, plant fibers, plastics, or any material capable of igniting and burning, whether flame-proofed or not, plastered or unplastered.
- **Non-combustible Material**  
Material which will not ignite and burn. Such materials are those consisting entirely of steel, iron, brick, tile, slate, glass or plasters, or any combination thereof.
- **Non-combustible Sealant Material**  
Sealants which will not ignite and burn: Rutland, Inc. Fireplace Mortar #63, Rutland 76R, Nuflex 304, GE RTV106 or GE RTB116 (or equivalent).

## C. Fuel Material and Fuel Storage

Pellet fuel quality can greatly fluctuate. This appliance has been designed to burn a wide variety of fuels, giving you the choice to use the fuel that is most economical in your region.

Hearth & Home Technologies strongly recommends only using Pellet Fuel Institute (PFI) certified fuel.

### Fuel Material

- Made from sawdust or wood by-products
- Shelled field corn & other biomass fuels
- Depending on the source material it may have a high or low ash content.

### Higher Ash Content Material

- Hardwoods with a high mineral content
- Fuel that contains bark
- Standard grade pellets, high ash pellets, corn and other biomass fuels

### Lower Ash Content Material

- Softwoods
- Fuels with low mineral content
- Premium grade pellets

### Shelled Field Corn

- Must be 15% or less moisture content.
- Must be clean and free from debris
- Never burn corn straight from the field
- Stalk parts, excessive fines and cob remnants, etc. will clog the auger mechanism
- Corn with excessive grain dust must be screened by sifting with 3/16 inch (4.7mm) mesh screening

**CAUTION! Do not burn fuel that contains an additive; (such as soybean oil).**

- May cause hopper fires
- Damage to product may result

*Read the ingredients list on the package. If you are buying corn or wheat the only ingredient that should be listed is corn or wheat.*

**WARNING! Risk of Chemical Poisoning!**

Do **NOT** burn treated seed corn

- Chemical pesticides are harmful or fatal if swallowed
- Burning treated seed corn will void your warranty

### Clinkers

Minerals and other non-combustible materials such as sand will turn into a hard, glass-like substance called a clinker when heated in the firepot.

Trees from different areas will vary in mineral content. That is why some fuels produce more clinkers than others.

### Moisture

Always burn dry fuel. Burning fuel with high moisture content takes heat from the fuel and tends to cool the appliance, robbing heat from your home. Damp pellet fuel can clog the feed system.

Size

- Pellets are either 1/4 inch or 5/16 inch (6-8mm) in diameter
- Length should be no more that 1-1/2 inches (38mm)
- Pellet lengths can vary from lot to lot from the same manufacturer
- Due to length variations, the flame height (feed rate) may need adjusting occasionally. See **page 25** for instructions..

Performance

- Higher ash content requires the ash drawer to be emptied more frequently
- Hardwoods require more air to burn properly
- Set wall control to “Utility Pellet” if the firepot and ash pan are filling quickly. This will cause the auto-clean system to empty the firepot more often.
- Premium wood pellets produce the highest heat output.
- Burning pellets longer than 1-1/2 inches (38mm) can cause an inconsistent fuel feed rate and/or missed ignitions.

We recommend that you buy fuel in multi-ton lots whenever possible. However, we do recommend trying various brands before purchasing multi-ton lots to ensure your satisfaction.

**CAUTION!** *Tested and approved for wood pellets, shelled field corn, wheat and black oil sunflower seeds. Burning of any other type of fuel voids your warranty.*

Changing to Different Fuel Type

- Empty the hopper of the previous fuel
- Thoroughly vacuum hopper before filling with the new fuel
- Select the appropriate setting on the FUEL SELECTION screen on the thermostat wall control

The burn rate, BTU content and heat output will all vary depending on the fuel selected.

Storage

- Wood pellets should be left in their original sealed bag until using to prevent moisture absorption.
- Shelled corn, wheat or sunflower seeds should be stored in a tight container to prevent it from absorbing moisture from damp or wet floors.
- This will also prevent rodents from becoming a problem.
- Do not store any pellet fuel within the clearance requirements or in an area that would hinder routine cleaning and maintenance.

**CAUTION**

Tested and approved for wood pellets, shelled field corn, wheat and black oil sunflower seeds. Burning of any other type of fuel voids your warranty.

**D. General Operating Information**

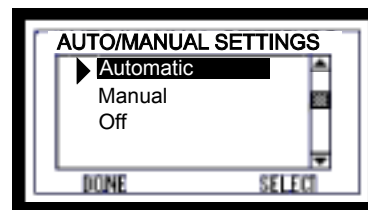
Read and understand the Thermostat Wall Control manual for detailed operating instructions. The wall control is an integral part of how to operate this appliance.

**1. Thermostat Wall Control - Automatic Setting**

The appliance is like most modern furnaces; when the thermostat wall control calls for heat, your appliance will automatically light and deliver heat.

When the room is up to temperature and the wall control is satisfied the appliance will shut down.

In the automatic setting the heat output level is controlled by the wall control. Select “Automatic” on the AUTO/MANUAL screen. **Figure 24.1.**

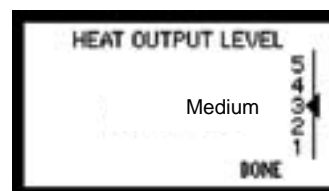


**Figure 24.1**

**2. Thermostat Wall Control - Manual Setting**

When you select “Manual” on the AUTO/MANUAL screen the appliance will still automatically turn on and off according to the temperature setting.

However, you will be able to manually control the heat output levels. Adjust the heat output levels by using the HEAT OUTPUT LEVEL screen. **Figure 24.2.**



**Figure 24.2**

**3. Auto-Clean Firepot System**

Your appliance is equipped with an automatic firepot cleaning system that will change the frequency of cleaning based on the fuel being burned.

The auto-clean system will clean itself immediately on initial plug in. If there is a power outage, as soon as power is restored it will recycle and clean itself if there is no fire in the firepot.

**NOTE:** User is responsible for removing the ash from the ash drawer.



**E. Before Your First Fire**

- First, make sure your appliance has been properly installed and that all safety requirements have been met.
- Pay particular attention to the fire protection, venting and thermostat wall control installation instructions.
- Double check that the ash pan, hopper and firebox are empty and then close the firebox door.

**NOTICE:** The tip of thermocouple must be in contact with the inside end of the thermocouple cover or missed ignitions can occur.

**F. Filling the Hopper with Fuel**

- Check the hopper and make sure it is empty before filling with fuel.
- Open the cast top hopper lid.
- Do not over fill the hopper. The hopper lid must be completely closed to maintain proper vacuum and for the feed motor to operate. An error ICON will appear on the wall control if the hopper lid is not properly closed.
- Do not leave any part of the fuel bag on the appliance after filling hopper.

**G. Starting Your First Fire**

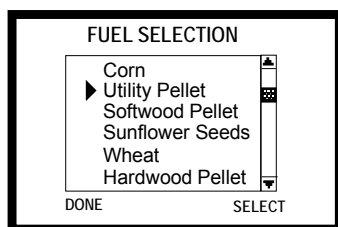
**1. Fuel Selection**

To start your first fire, you must:

- Select the appropriate fuel on the FUEL SELECTION screen on the thermostat wall control to match the fuel you have chosen to burn.
- If the proper fuel is not selected your appliance will not operate properly.
- For example, if you have selected wood pellets and you are burning corn, the appliance may not light, it may go out or overfeed. **Figure 25.1.**

**NOTE:** If you are lighting your appliance for the first time:

- The feed tube will be empty and it can take some time to fill it with fuel before you will see a fire
- Put a handful of fuel in the firepot (priming) to speed up the process. You can also do this when you have run completely out of fuel.



**Figure 25.1**

**2. Comfort Level Selection**

Once your fuel is selected, select the temperature at the desired setting on the SET COMFORT LEVEL screen. **Figure 10.2.**



**Figure 25.2**

**3. Automatic or Manual Setting**

The automatic setting will control the heat output based on the comfort level selection. The manual setting allows you to manually control the heat output settings. **See page 27, Ignition Cycles.**

**NOTE:** See the Wall Control Thermostat manual for detailed instructions.

**H. Fire Characteristics and Flame Height (Feed Rate) Adjustment**

A properly adjusted fire will have an active flame pattern and the flame will rise and fall somewhat. This is normal.

- On HIGH setting, the flame will extend approximately 8 inches (203mm) out of the firepot. If it is not 8 inches (203mm) tall, increase the flame height.
- On MEDIUM or LOW setting the flame will be shorter.
- Reduce the flame height if the fire has tall flames with black tails and seems somewhat lazy. This may also indicate that the firepot and/or heat exchanger needs to be cleaned. Refer to **Section 10** for Maintenance and Cleaning Instructions.

Adjusting the Flame Height (Feed Rate)

- Set your appliance to “MANUAL” mode on the wall control.
- Set the heat output level to HIGH.
- Adjust the flame height using the “FLAME HEIGHT ADJUST” screen on the wall control. **Figure 25.3.**



**Figure 25.3**

## I. Battery Back-up System (Optional)

### CAUTION!

- Hook up to battery terminals BEFORE you plug battery into appliance.
- Damage to internal electronic components may occur.

The appliance has been designed to operate on an optional battery back-up system.

If you have frequent power outages in your region, hook the appliance up to a 12 volt battery and it will automatically switch to battery power in the event of a power failure. The 12 volt power cord, sold as a separate accessory, does not charge the battery.

### WARNING! Risk of Injury!

- Blowers may continue to run and would be exposed to human contact.

#### Operating on Battery Back-Up

- A battery icon appears on your wall control to let you know you are now operating on battery power. **Figure 26.2.**
- The fire must be manually lit as the appliance will no longer automatically light. Follow the instructions in the Wall Control Manual.
- Use only approved fire starting gel to start the fire.
- The high burn rate is no longer available on battery back-up.
- Each level drops down one level, i.e the high burn becomes medium-high burn and so on.
- If the battery charge falls below 10 volt it can no longer sustain the appliance operation and the appliance will shut down. **Figure 26.1.** You must disconnect and re-connect the battery to start it up again.

#### Recommended Battery

- 12 volt deep cycle battery, (i.e., marine or RV type).
- A 12 volt battery cable is available through your local dealer.

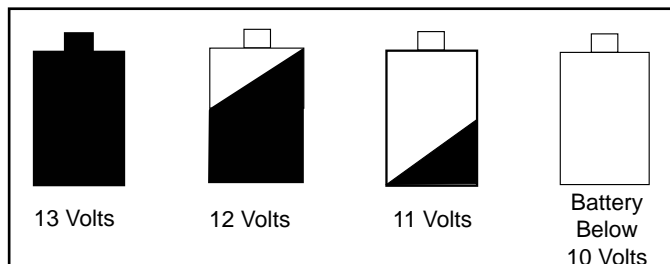


Figure 26.1

#### Wall Control Display

The wall control will display the battery icon when operating in the battery back-up mode. **Figure 26.2**

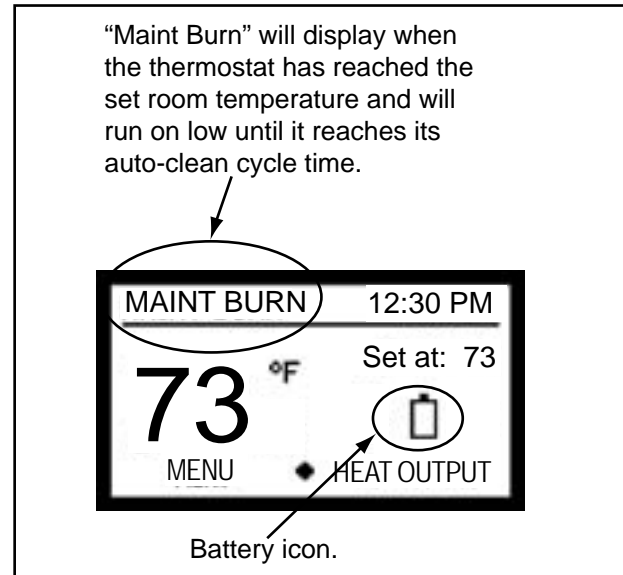


Figure 26.2

## J. Clear Space

**WARNING! RISK OF FIRE!** Do NOT place combustible objects in front of the appliance. High temperatures may ignite clothing, furniture or draperies. Maintain a minimum clearance of 3 feet (914mm) in front of appliance.

**Mantel:** Avoid placing candles and other heat-sensitive objects on mantel or hearth. Heat may damage these objects.

**NOTICE:** Clearances may only be reduced by means approved by the regulatory authority having jurisdiction.

**WARNING! RISK OF FIRE!** Keep combustible materials, gasoline and other flammable vapors and liquids clear of appliance.

- Do NOT store flammable materials in the appliance's vicinity.

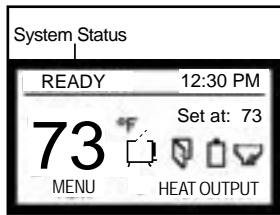
DO NOT USE GASOLINE, LANTERN FUEL, KEROSENE, CHARCOAL LIGHTER FLUID OR SIMILAR LIQUIDS TO START OR "FRESHEN UP" A FIRE IN THIS HEATER.

- DO NOT BURN GARBAGE OR FLAMMABLE FLUIDS SUCH AS GASOLINE, NAPHTHA OR ENGINE OIL.
- DO NOT USE CHEMICALS OF FLUIDS TO START THE FIRE.

Keep all such liquids well away from the heater while it is in use as combustible materials may ignite.

**K. Ignition Cycles**

The appliance engine is controlled by the digital thermostat wall control. The digital display on the wall control will tell you what your appliance is doing in the upper left corner (System Status). **Figure 27.1.**



**Figure 27.1**

Every time the thermostat calls for heat, the appliance steps through five cycles:

1	Start-Up Cycle	4	Shutdown Cycle
2	Soft-Start Cycle	5	Auto-Clean Cycle
3	Heating Cycle		

The duration and characteristics of these cycles may be different with each type of fuel selected.

**WARNING! RISK OF FIRE!**

Do **NOT** operate appliance:

- With appliance door open
- With firepot floor open
- With ash pan removed

**1. Start-Up Cycle**

During this cycle:

- Igniter turns on for 90 seconds to heat up the air in the firepot
- Combustion blower starts
- Vacuum switch comes on
- Feed motor turns on adding fuel to the firepot and the appliance waits for the fire to start

The duration of start-up depends on the type and quality of fuel used. It is normal to see some smoke during the ignition process as moisture evaporates and the fuel lights. The smoke will stop once the fire starts.

**2. Soft Start Cycle (SS-Low / SS-Med)**

Once the fire is lit:

- The appliance moves into the low soft-start cycle as it continues to build the fire
- More fuel will be added
- As the fire builds, the appliance will change to medium soft-start mode
- The heating cycle begins

**3. Heating Cycle ( Auto / Man - L, ML, M, MH, H)**

There are two choices in the Automatic / Manual menu of how your appliance will operate:

**Automatic Mode**

- The wall control will turn the heat output level up or down depending on how far the room temperature is from the desired temperature
- The digital display will read AUTO:M, i.e. automatic-medium level
- As the room temperature approaches the desired temperature, the appliance will turn down to lower settings
- When the home reaches your set temperature, the appliance will go into the shutdown cycle

**Manual Mode**

- Set the heat output setting from the main screen
- The right bottom button will read HEAT OUTPUT
- You can operate the appliance from any of the 5 levels
  - On the lowest level (MAN: L) the appliance will stay on longer, burn less fuel per hour, and will take longer to bring the home up to your desired temperature
  - On the highest setting (MAN:H) the appliance will burn more fuel per hour, and bring your home up to temperature more quickly
- In Manual mode the heat output does not change but will stay at the setting you chose until the comfort level is reached (meaning the thermostat has been satisfied). Turn to OFF to stop operation.

**4. Shutdown Cycle**

Once your home has reached your set temperature:

- Appliance will stop feeding fuel and allow the fire to diminish
- Convection blower will continue to run until the appliance cools to appropriate temperature
- Appliance will begin the auto-clean cycle

### 5. Auto-Clean Cycle

The firepot auto-clean system will cycle:

- When the appliance is first plugged in
- When the house reaches temperature and the appliance shuts down
- At prescribed intervals, depending on the type of fuel selected
- When starting up after an electrical interruption

If your appliance is running and the auto-clean cycle is initiated, the appliance will revert to shutdown cycle.

- The floor of the firepot will open and dump the ash into the ash pan
- It takes approximately 2 minutes to complete the auto-clean cycle
- The floor will then shut, and if the thermostat is still calling for heat, the fire will start again
- During this auto-clean cycle, the convection blower may continue to run. The combustion blower will continue to run.

#### Additional Screen Messages:

**READY** It is telling you that the home is up to temperature and doesn't need any heat.

**- - - - -** The screen will show 5 dashes when the wall control and the control board are NOT communicating with each other. Check that the wiring on the thermostat is properly connected.

**MAINTENANCE BURN** This indicates the appliance is operating on battery backup, prior to the auto-clean. The maintenance burn will keep the system from shutting down as the appliance will not automatically re-light in battery back-up mode.

**OFF** The AUTO/MANUAL SETTING screen has been set to OFF. Set the appliance to OFF when performing periodic maintenance to prevent an unexpected startup.

**BLANK SCREEN** The ON/OFF switch may be in OFF position. Turn to ON position.



### WARNING



#### Fire Risk

Do NOT operate appliance:

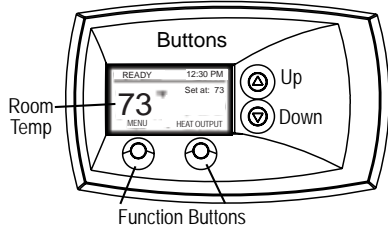
- With appliance door open.
- With firepot floor open.

Do NOT store fuel:

- Closer than required clearances to combustibles to appliance.
- Within space required for loading or ash removal.

**L. Quick Start Guide**

**NOTICE:** Any button pressed will turn on the backlight. Wall control will automatically revert back to the starting screen if there is no activity for 15 seconds; except for the “CONFIRM FUEL CHANGE” screen.



**Wall Control for Reference**

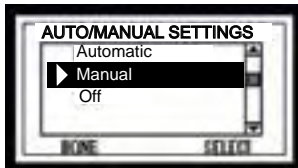
**TURNING ON APPLIANCE**



1. At the starting screen, press “MENU”.

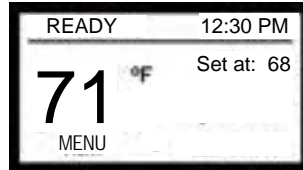


2. Highlight “AUTO/MANUAL/OFF”. Press “SELECT”.



3. Highlight “MANUAL”. Press “SELECT”.
4. Press “DONE” twice or wait 15 seconds for starting screen to re-appear.

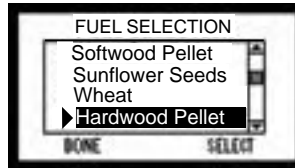
**CHOOSING FUEL TYPE**



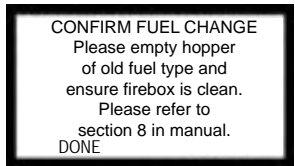
1. At the starting screen, press “MENU” button once or twice until “MENU” screen appears.



2. Highlight “FUEL TYPE” using the “UP/DOWN” buttons to the right side of the display. Press “SELECT”.



3. Scroll down and highlight “HARDWOOD PELLETT” or your fuel type.
4. Now press “SELECT” to choose new fuel.



5. Press “DONE” to confirm fuel change.
6. Press “DONE” twice or wait 15 seconds for starting screen to re-appear.
7. Fill the hopper with fuel. If the hopper was completely empty or has run out of fuel, put approximately 1/2 cup of pellets into the firepot for a quick restart.
8. Be sure the hopper lid and glass door are both closed.

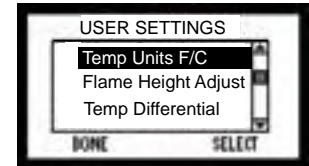
**CHOOSING TEMP UNIT:  
°F or °C**



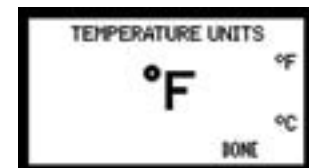
1. At the starting screen, press “MENU” button once or twice until “MENU” screen appears.



2. Highlight “USER SETTINGS” using the “UP/DOWN” buttons to the right side of the display. Press “SELECT”.



3. Highlight “TEMP UNITS F/C” using the “UP/DOWN” buttons to the right side of the display. Press “SELECT”.



4. Press the “UP” or “DOWN” button to set desired temperature unit and press “SELECT”..
5. Press “DONE” twice again, or wait 15 seconds for starting screen to re-appear.

**SETTING COMFORT LEVEL**



1. Press and hold "UP" or "DOWN" button to set desired temperature.

**NOTE:** Set temperature must be 3 degrees higher than room temperature for appliance to start.



2. Press "HOLD TEMP".



3. Press "DONE".

**SETTING HEAT OUTPUT**



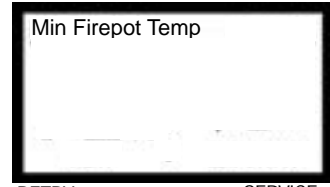
1. At the starting screen, press "HEAT OUTPUT".



2. Use the "UP" button to change "HEAT OUTPUT LEVEL" to "MEDIUM-HIGH".
3. Press "DONE" twice or wait 15 seconds for starting screen to re-appear.

**HOPPER OUT OF FUEL**

**ERROR LIST**



1. If the appliance has stopped operating, check the wall control screen. If it is showing "Min Firepot Temp" the hopper has run out of fuel.
2. Fill the hopper with fuel and press the "RETRY" button twice. The first time turns on the back light, the second time starts the retry function.



3. If the wall control screen changes to a "SHUTDOWN" screen that means your appliance has not completed the full shutdown cycle. Depending on where it was in the cycle it can take from one to ten minutes to restart.

When the shutdown cycle is complete the wall control screen will display "STARTUP". Continue to Step 4.



4. If the wall control screen changes to a "STARTUP" screen after pressing "RETRY" that means your appliance has already completed the shutdown cycle. You must wait until the wall control screen displays the startup screen and then put 1/2 cup of pellets in the firepot for a quick restart.
5. Be sure the hopper lid and glass door are both closed.

**M. Frequently Asked Questions**

<b>ISSUES</b>	<b>SOLUTIONS</b>
1. Metallic noise	1. Noise is caused by metal expanding and contracting as it heats up and cools down, similar to the sound produced by a furnace or heating duct. This noise does not affect the operation or longevity of your appliance.
2. Ash build-up on glass	2. This is normal. Clean the glass.
3. Glass has turned dirty	3. Excessive build up of ash. The lower burn settings will produce more ash, the higher burn settings produce less. The more it burns on low the more frequent cleaning of the glass is required.
4. Fire has tall flames with black tails and is lazy	4. The flame height adjustment needs to be reduced or the firepot needs cleaning. Heat exchanger or exhaust blower needs cleaning.
5. Excessive smokey start-up	5. Either the firepot is dirty or there is too much fuel at start-up and not enough air.
6. Large flame at start-up	6. This is normal. Flame will settle down once the fire is established. Some smoke is normal.
7. Mechanical Noise	7. The floor of the firepot in the auto-clean system may make some noise as it scrapes the ash into the ash pan.

**CAUTION**



Odors and vapors released during initial operation.

- Curing of high temperature paint.
- Open windows for air circulation.

Odors may be irritating to sensitive individuals.

# 9 Troubleshooting

With proper installation, operation, and maintenance your appliance will provide years of trouble-free service. If you do experience a problem, this troubleshooting guide will assist a qualified service person in the diagnosis of a problem and the corrective action to be taken. This troubleshooting guide can only be used by a qualified service technician.

Error Message	Possible Cause	Corrective Action
	Bad wall control or control board 3 wires have loose connections or installed wrong	Replace wall control or control board Check connections
BAD TC DROP TUBE (TC = Thermocouple)	Drop tube thermocouple is broken or leads are reversed	Check connections Replace thermocouple
BAD TC FIREPOT (TC = Thermocouple)	Firepot thermocouple is broken or leads are reversed	Check connections Replace thermocouple
SNAP DISC TRIPPED	Overheat sensor (snap disc) has tripped  Convection blower may need cleaning	Turn power off to appliance and manually reset snap disc then turn power back on  Clean convection blower if needed
VACUUM SW ERROR (SW = Switch)	Vacuum switch is bad  Vacuum hose is plugged/disconnected	Check connections. Bypass vacuum with jumper wire, if runs, switch is bad. Replace switch  Check vacuum hose
COMB BLOWER JAMMED	Combustion blower is blocked/jammed	Remove blockage Replace blower if necessary Must unplug appliance to clear error
AUGER JAMMED	Auger jammed, feed motor bad	Pull the feed system and inspect Clear jam and Press Retry
MISSED IGNITION	Igniter bad or poor harness connection Out of fuel or fuel is bridging in hopper Faulty firepot thermocouple connection has shorted.	Check connections, if OK replace igniter Break up bridging pellets. Refill hopper Replace the thermocouple Press Retry
MIN FIREPOT TEMP	Out of fuel	Refill hopper Add handful of pellets to firepot to prime it Press Retry
MAX DROP TUBE TEMP	Appliance in over-heat condition Flame height set too high Components may need cleaning	Confirm setting matches burning fuel Adjust flame height Clean the firebox, heat exchanger, convection blower, firepot and ash pan
CONV BLOWER JAMMED	Convection blower blocked/jammed	Remove blockage Replace blower if necessary Must unplug appliance to clear error
CHECK ASHPAN	Auto-clean jammed  Auto-clean switch is bad Linkage has become disconnected	If ashpan is empty, check for a jam. Use a screw driver and firmly push in the firepot floor holes and flex spring and push toward home to release jam  Replace switch Reconnect linkage
SCREEN GOES BLANK	Static discharge or nearby lightning or Electric fast transients at the input mains	Wait 25 seconds and press any key to refresh the screen.
	Hopper lid not closed all the way Switch is out of adjustment (auger will not function)	Close the lid. If that didn't work replace the switch Adjust or replace switch
	Firebox door is not latched properly	Adjust or replace door switch
	Out of fuel	Check the fuel level, if OK the switch may be out, replace switch



# 10 Maintaining & Servicing Your Appliance

## A. Proper Shutdown Procedure

1. Set wall control to OFF on AUTOMATIC / MANUAL SETTING screen. **Figure 33.1.**
2. Wall control screen will scroll through the following messages after setting to OFF.
  - Shutdown
  - Auto-Clean
  - Off
3. Smoke spillage into the room can occur if the appliance is not cool before unplugging.
4. There is a risk of shock if the appliance is not unplugged before servicing the appliance.

After servicing, restart with the AUTO/MANUAL SETTINGS screen. **Figure 33.1.**

## Before Servicing Your Appliance

### CAUTION! SHOCK AND SMOKE HAZARD!

- Proper Shutdown Procedure must be followed.
- Smoke spillage into room can occur if appliance is not cool before unplugging appliance.
- Risk of shock if appliance is not turned off before servicing appliance.

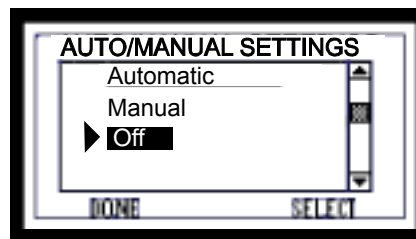


Figure 33.1

*Follow the detailed instructions found in this section for each step listed in the chart below.*

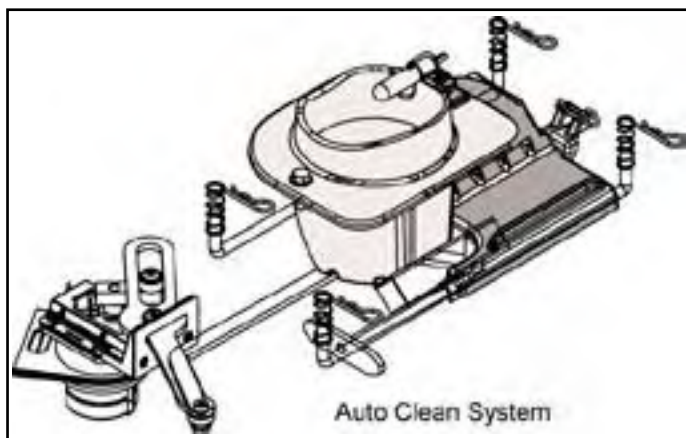
## B. Quick Reference Maintenance Chart

Cleaning or Inspection	Frequency		Daily	Weekly	Every 2 Weeks	Monthly	Yearly
Ash Pan - Burning Wood Pellets	Every 5 bags of fuel	OR		X			
Ash Pan - Burning Alternate Fuels	Every 1 bag of fuel	OR	X				
Ash Removal from Firebox	More frequently depending on the fuel type or ash build-up	OR		X			
Auto-Clean Inspection	More frequently depending on the fuel type	OR				X	
Blower, Combustion (Exhaust)	More frequently depending on the fuel type	OR					X
Blower, Convection	More frequently depending on the fuel type	OR					X
Door Latch Inspection	Prior to heating season	OR				X	
Firebox - Prepare for Non-Burn Season	At end of heating season	OR					X
Firepot - Burning Softwood Pellets	Every 5 bags	OR		X			
Firepot - Burning Hardwood Pellets	Every 3 bags	OR		X			
Firepot - Burning Alternate Fuels	Every 1 bag	OR	X				
Glass	When clear view of firepot becomes obscured	OR		X			
Heat Exchanger & Drop Tube	Every 1 ton of fuel	OR			X		
Hopper	Every 1 ton of fuel or when changing fuel types	OR				X	
Venting System	More frequently depending on the fuel type	OR					X

**NOTICE:** These are recommendations. Clean more frequently if you encounter heavy build-up of ash at the recommended interval or you see soot coming from the vent. Not properly cleaning your appliance on a regular basis will void your warranty.

**C. General Maintenance and Cleaning****1. Auto-Clean System Inspection & Cleaning**

- **Frequency:** Monthly or every ton (aprx. 50 bags) or more frequently depending on the type of fuel
- **By:** Homeowner
  - a. Be sure the wall control screen says OFF and the appliance is allowed to cool.
  - b. Open the firebox door. Inspect the auto-clean springs: (**See item #59 on page 46** for the location of the springs).
    - Inspect for any degradation or deformation
    - As the springs heat up and cool down they can lose tension
    - If there is a gap showing above the firepot bottom, approximately 1/16 inch (1.59mm) or more, it means the springs have lost their tension
    - Lost tension can not keep the floor in the proper position causing ignition problems and fuel falling into the ash pan.
    - Call your dealer to replace the springs.
  - c. Inspect the holes in the firepot floor for any debris.
    - The holes must be kept clear.
  - d. How often the firepot cleans itself depends on:
    - The type of fuel you selected on the thermostat wall control
    - How long the appliance burns before satisfying set point on wall the control.
    - Burning biomass fuels may require a more thorough cleaning during the burn season.
  - e. Excessive clinkers will eventually jam the auto-clean system and generate an error message on the wall control.

**Figure 34.1****2. Ash Removal from Firebox**

- **Frequency:** Weekly or more frequently depending on ash build-up
- **By:** Homeowner

Be sure the wall control screen says OFF and the appliance is allowed to cool.

There must not be any hot ashes in the firebox during cleaning.

Frequent cleaning of the ash in the firebox with a vacuum cleaner will help slow down the build-up of ash in the exhaust blower and vent system.

**3. Cleaning Ash Pan**

- **Frequency:** Weekly or every 3-5 bags
- **By:** Homeowner
  - a. Locate the ash pan underneath the firepot.
  - b. Slide the ash pan straight out.
  - c. Empty into a non-combustible container and re-install ash pan.
  - d. When replacing ash pan push it back until it catches on the 2 side latches.
  - e. Clinkers filling the ash pan will have to be cleaned out more often than ash. **See Disposal of Ashes.**

**4. Disposal of Ashes**

- **Frequency:** As needed
- **By:** Homeowner
  - a. Ashes should be placed in a metal container with a tight-fitting lid.
  - b. The closed container of ashes should be placed on a non-combustible floor or on the ground, well away from all combustible materials, pending final disposal.
  - c. If the ashes are disposed of by burial in soil or otherwise locally dispersed, they should be retained in the closed container until all cinders have been thoroughly cooled.

**WARNING! RISK OF FIRE!** Keep combustible materials, gasoline and other flammable vapors and liquids clear of appliance.

- Do **NOT** store flammable materials in the appliance's vicinity.
- Do **NOT** use gasoline, lantern fuel, kerosene, charcoal lighter fluid or similar liquids to start or "freshen up" a fire in this heater.

Keep all such liquids well away from the heater while it is in use as combustible materials may ignite.

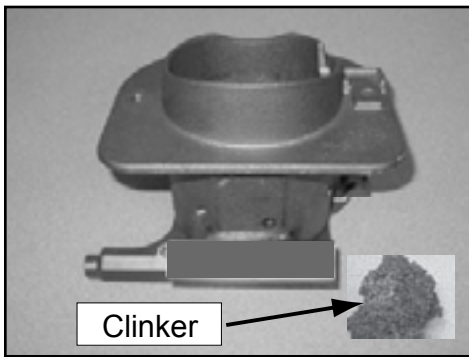
**WARNING! RISK OF FIRE!**

Do **NOT** store fuel:

- Closer than required clearances to combustibles to appliance.
- Within space required for loading or ash removal.

**5. Cleaning Firepot with Firepot Clean-Out Tool**

- **Frequency:**  
**Softwood Pellets:** Weekly or every 5 bags  
**Hardwood Pellets:** Weekly or every 3 bags  
**Alternate Fuel:** Daily or every 1 bag
  - **By:** Homeowner
- a. Be sure the wall control screen says OFF and the appliance is allowed to cool.
  - b. It may be necessary to use your firepot clean-out tool to chip away material that has built up on the sides of the firepot and to push out any clinkers.
    - Larger clinkers may have to be removed from the top of the firepot.
    - If the clinker adheres to the sides of the firepot, you will need to manually clean the firepot.
  - c. After power is restored, the auto-clean system will recycle and then clean itself.
  - d. The firepot floor plate must be fully closed when finished.



**Figure 35.1 - Large Clinker**

**6. Cleaning Heat Exchanger, Drop Tube & Exhaust**

- **Frequency:** Monthly or every 1 ton of fuel (aprx. 50 bags).
- **By:** Homeowner

NOTE: There are heavy duty vacuum cleaners specifically designed for solid fuel appliance cleaning.

***WARNING! Hopper Fire Risk!***

*For trouble free use of your pellet appliance you must perform cleaning as called for in these instructions. Not doing so will result in:*

- Poor operating performance
- Smoke spillage into the home
- Overheating of components

Not properly cleaning your appliance on a regular basis will void your warranty.

**Tools Needed:** A Shop Vac and generic micro cleaning kit; flat head and Phillips screwdriver; 11/32 Nut-driver or wrench.



**Shop Vac\* Example**



**Micro Cleaning Kit\* Example**

**\* Can be purchased at your local hardware store.**

- a. It is necessary to remove the baffle to gain access to the heat exchanger. Follow instructions for baffle removal on **page 39**.
- b. Vacuum the ash from the heat exchanger with an upholstery brush to remove the majority of the ash. Be sure to vacuum the back of the baffle also. Inspect the drop tube and remove any residue build-up in the drop tube. **Figure 35.3**.

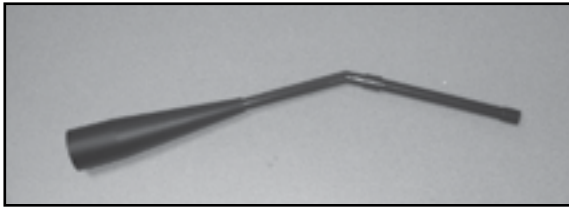


**Figure 35.2 - Example of a dirty heat exchanger**



**Figure 35.3**

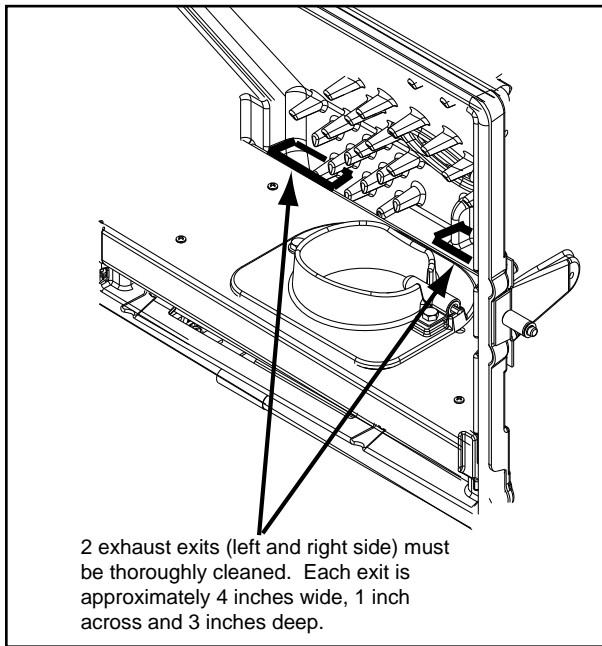
- c. Assemble the crevice tool from the micro cleaning kit to attach to a Shop Vac. **Figure 36.1.**



**Figure 36.1**

- d. Use the crevice tool to finish cleaning the heat exchanger fins. It is critical that the 2 exhaust exits at the back of the firebox floor (left and right) be thoroughly cleaned. **Figure 36.2.** There are several ways this can done.

1. Use the crevice tool.
2. Attach a hose 1/2 inch (12.7mm) in diameter and approximately 2 feet (607mm) in length to your vacuum hose.
3. Use a bottle brush and push the ash down to the bottom. Remove the combustion (exhaust) blower and then vacuum out the ash.

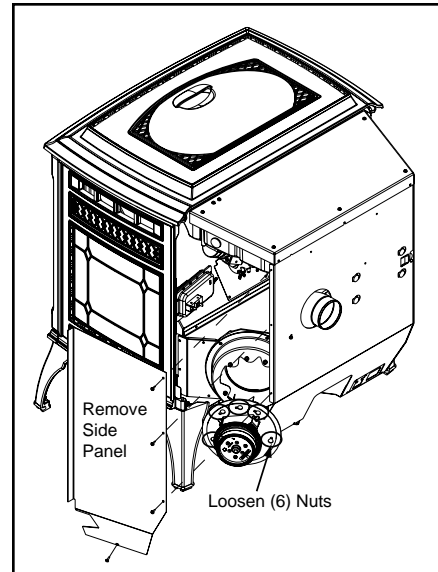


**Figure 36.2**

**NOTE** It is normal to see a certain amount of wear of the heat exchanger fins. You may notice some flaking and pitting on some of the pins. The heat exchanger system will function as designed with as many as 15 of these pins missing.

- f. Removing the Combustion (Exhaust) Blower

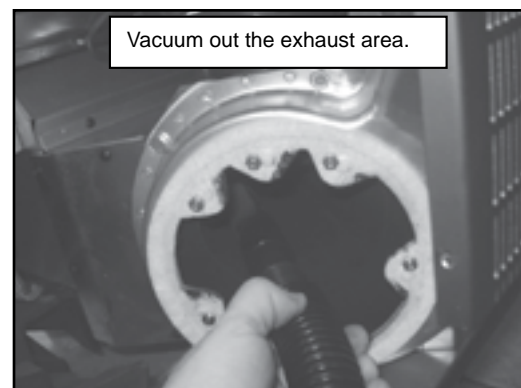
1. The combustion blower is mounted in the bottom right rear of the appliance. **Figure 36.3.**
2. Remove side panel and then using an 11/32 nut driver to loosen all six nuts, but do not remove. Rotate the blower and remove from the housing. **Figure 36.4.**
3. Set the blower on the top of the housing. You do not need to disconnect the wires.
4. Vacuum out the exhaust area. **Figure 36.5.**



**Figure 36.3**



**Figure 36.4**



**Figure 37.2**

**7. Cleaning the Hopper**

- **Frequency:** Monthly or after burning 1 ton of fuel, (aprx 50 bags) or when changing fuel types
  - **By:** Homeowner
- a. Be sure the wall control screen says OFF and the appliance is allowed to cool.
  - b. After burning approximately 1 ton of fuel you will need to clean the hopper to prevent sawdust and/or fines build-up.
  - c. A combination of sawdust/fines and pellets on the auger reduces the amount of fuel supply to the firepot.
  - d. This can result in nuisance shut downs and misstarts
    - Empty the hopper of any remaining pellets.
    - Vacuum the hopper and feed tube.

**8. Cleaning the Glass**

- **Frequency:** When clear view of firepot becomes obscure
  - **By:** Homeowner
- a. Be sure the wall control screen says OFF and the appliance is allowed to cool.
  - b. Clean glass with a non-abrasive commercially available cleaner. Wipe down with dry towel.

**9. Door Latch Inspection**

- **Frequency:** Prior to heating season
- **By:** Homeowner

The door latch is non-adjustable but the gasketing between the glass and firebox should be inspected periodically to make sure there is a good seal. If the gasket is frayed or damaged, replace with a new one.

**10. Cleaning Exhaust Blower - Requires No Lubrication**

- **Frequency:** Yearly or as needed
  - **By:** Homeowner
- a. Be sure the wall control screen says OFF and the appliance is allowed to cool.
  - b. Use a soft brush and vacuum to clean the propellers.

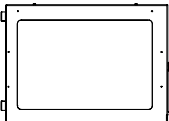
**11. Cleaning Convection Blower - Requires No Lubrication**

- **Frequency:** Yearly or as needed
  - **By:** Homeowner
- a. Be sure the wall control screen says OFF and the appliance is allowed to cool.
  - b. Use a soft brush and vacuum to clean the propellers.

**12. Cleaning the Top Vent Adapter (if installed)**

- **Frequency:** As Needed
  - **By:** Homeowner
- a. Be sure the wall control screen says OFF and the appliance is allowed to cool.
  - b. Open the clean out cover. **Figure 38.1.**
  - c. Sweep out any ash build-up.

**CAUTION**




Handle glass assembly with care.

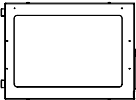
**When cleaning glass door:**

- Avoid striking, scratching or slamming glass.
- Do NOT clean glass when hot.
- Do NOT use abrasive cleaners.
- Use a hard water deposit glass cleaner on white film.

Refer to maintenance instructions.

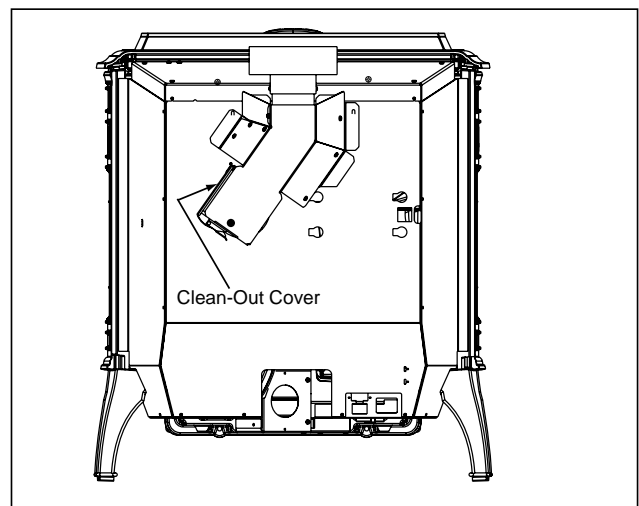


**WARNING**



Handle glass doors with care.

- Inspect the gasket to ensure it is undamaged.
- Do NOT strike, slam or scratch glass.
- Do NOT operate appliance with glass door removed, cracked, broken or scratched.



**Figure 37.1**

**13. Soot and Fly Ash: Formation & Need for Removal in Exhaust Venting System.**

- **Frequency:** Prior to each burn season and after prolonged shut down.
- **By:** Qualified Service Technician/Homeowner

The products of combustion will contain small particles of fly ash. The fly ash will collect in the exhaust venting system and restrict the flow of the flue gases. At start-up if there is incomplete combustion, or if there is a shut-down or incorrect operation of the appliance it will lead to some soot formation. This will collect in the exhaust venting system.

The venting system may need to be cleaned at least once a year or more often depending upon the quality of your fuel or if there is a lot of horizontal pipe sections. Ash will build up more quickly in the horizontal sections.

**14. Preparing Firebox for Non-Burn Season**

- **Frequency:** Yearly at end of burn season
- **By:** Homeowner
  - a. The appliance must be in complete shutdown and allow the appliance to completely cool down.
  - b. Remove all ash from firebox and vacuum thoroughly.
  - c. Paint all exposed steel, including cast-iron. Use the Touch-Up paint supplied with the appliance or purchase paint from your local dealer. You must use a high-temperature paint made specifically for heating appliances.
  - d. Cleaning the flue at the end of the burn season will prevent corrosives to build-up and damage the flue.
  - e. Outside temperatures should have no affect on the performance of the appliance under freezing conditions.

**D. High Ash Fuel Content Maintenance**

- **Frequency:** When the ash build-up exceeds the half way point in the firepot
- **By:** Homeowner

If the ash build-up exceeds the half way point in the firepot before it automatically cleans, then the firepot is not being cleaned often enough.

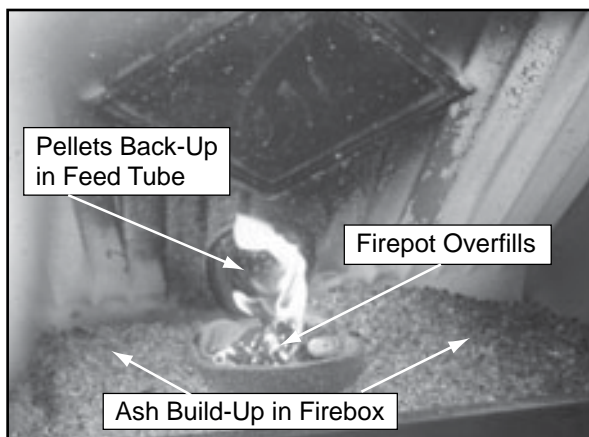
Another symptom is if clinkers are adhering to the sides of the firepot.

Double check the wall control to ensure the proper setting has been selected for the fuel you are burning. If that is correct, change the setting to **“Utility Pellet”**.

**NOTE:** You will need to empty the ash pan more frequently if using the **“Utility Pellet”** setting.

**WARNING! Risk of Fire and Smoke!**

- High ash fuels or lack of maintenance can cause firepot to overflow. Follow proper shutdown procedure if ash buildup exceeds half way point in firepot.
- Failure to do so could result in smoking, sooting and possible hopper fires.

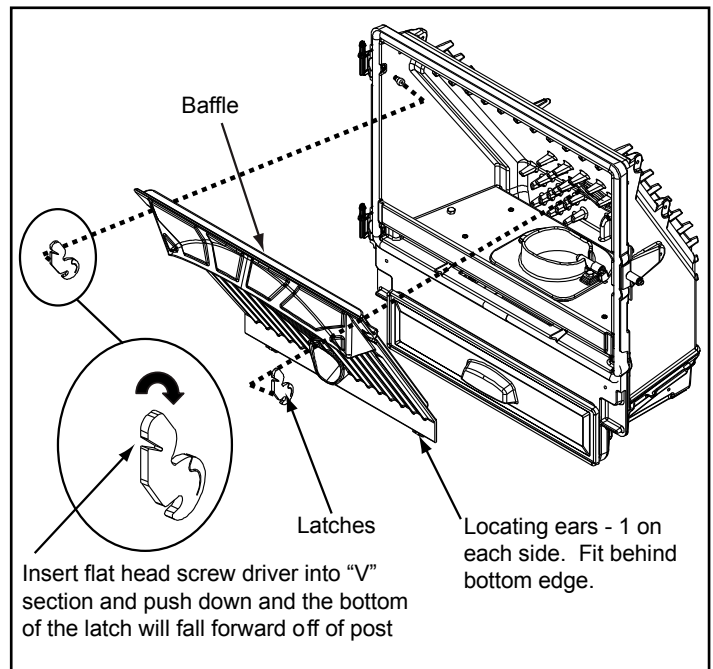


**Figure 39.1**

**E. Baffle Removal**

		<p><b>WARNING</b></p>
<p><b>Cast iron is a very heavy material.</b> The baffle is made of cast iron and therefore is heavy and awkward at times to maneuver. Clear and prepare your work area before you begin.</p>		

- The appliance must be in complete shutdown, completely cool and the exhaust blower off.
- Open door.
- The baffle is located at the top inside of firebox.
- Remove baffle by placing a flat head screw driver into the slot of the latches located in the upper corners and push down. The bottom of the latch will fall forward off of the post. Lift the baffle up and then out toward you. **Figure 39.2.**
- To replace the baffle, place the 2 locating ears behind the bottom edge and tilt the baffle up and into place.
- The baffle must be centered in the firebox before latching it in place. If it is not centered the latch is trapped between the baffle and side of the firebox instead of latching properly.
- The bottom of the latches will fit over the posts. Push the top of the latch forward to lock latch into place.



**Figure 39.2**

## F. Convection Blower Replacement

1. Follow the proper shut down procedures as outlined on **page 33, Section 10.A.**
2. Remove the left and right side panels by removing the 4 screws using a Phillips head screw driver. **Figure 40.1.**
3. Depress the tab on the left side and snap out the power supply. You do not need to disconnect any wires. **Figure 40.1.**
4. Remove the 2 screws at the bottom of the back panel so there will be room to remove the blower. **Figure 40.1**
5. Reach behind the blower and release the latch by pushing the top of the latch towards the blower. **Figure 40.2.**
6. Rock the top of the blower slightly and lift up. The blower will pass around the control board and out the left side of the appliance.
7. Disconnect the wire harness from the bottom of the blower by depressing the tabs on the sides of the connector and then pulling to remove. **Figure 40.1.**
8. Re-connect wire harness to the new blower.
9. Install replacement blower by placing the bottom flange into the opening first then rotate blower up into position.
10. When the blower is properly positioned the latch will engage the notch to hold the blower in place. **Figure 36.3.**
11. Re-secure the back panel, snap the power supply back in and re-secure the side panel(s).

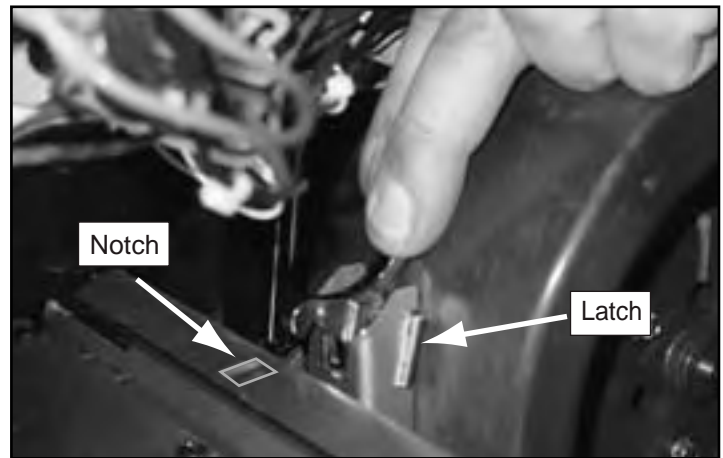


Figure 40.2

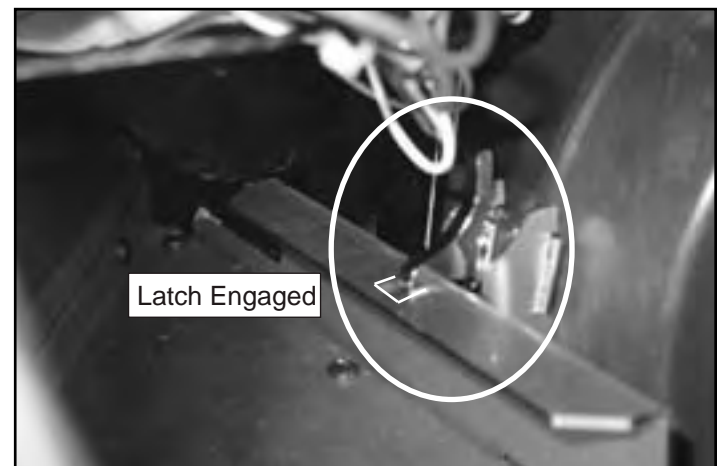


Figure 40.3

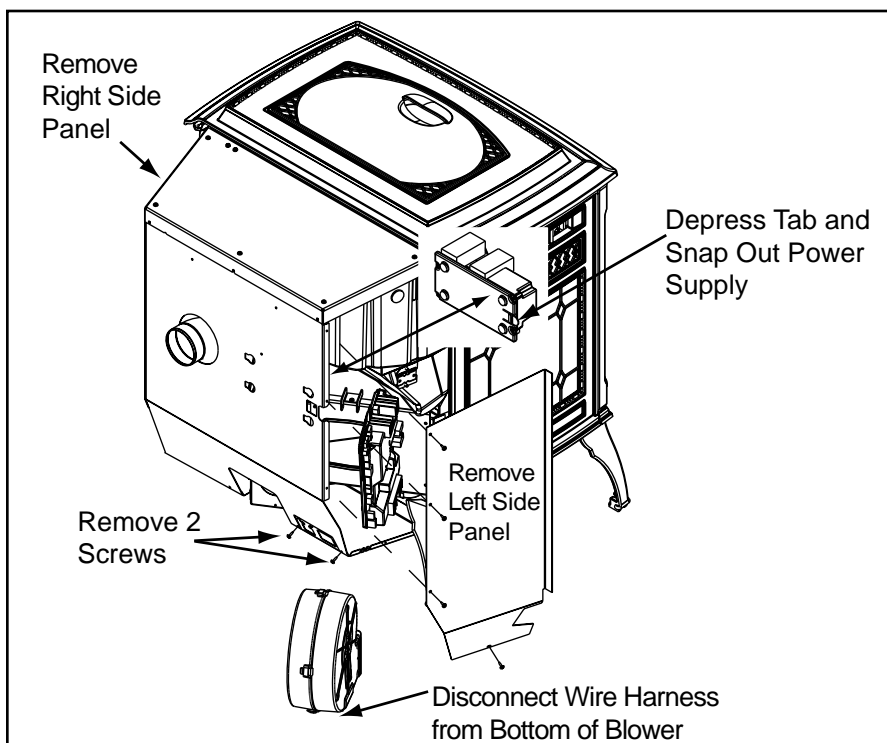
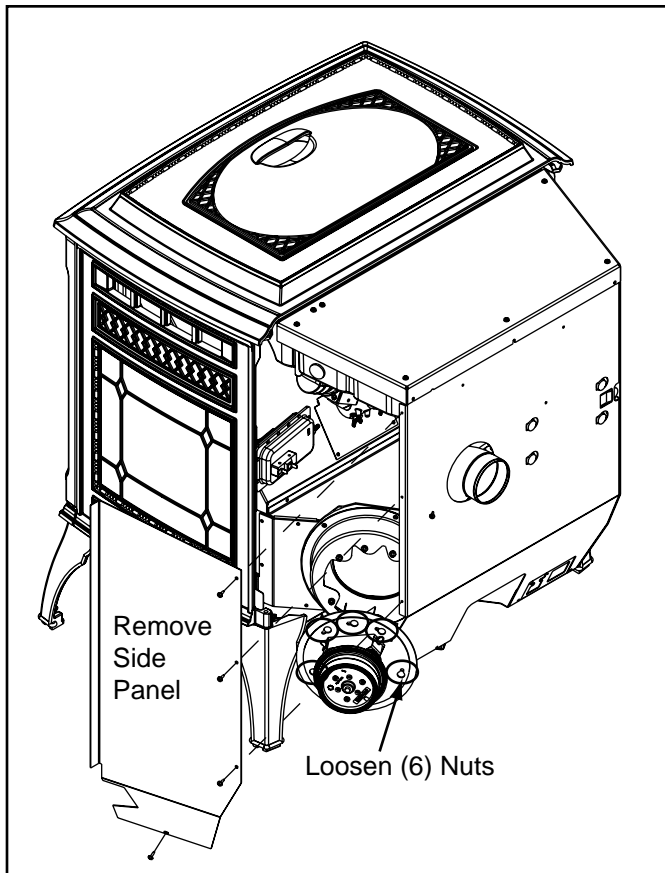


Figure 40.1



**G. Combustion (Exhaust) Blower Replacement**

1. Follow the proper shut down procedures as outlined on **page 33, Section 10.A.**
2. Remove the right side panel by removing the 4 screws using a Phillips head screw driver. **Figure 41.1.**
3. It is not necessary or recommended to remove the housing to replace or service the combustion blower. You only need to remove the motor and impeller.
4. Disconnect the wire from the control board connection points #1 and #8. Depress the tab on the connector to disconnect the wire (similar to a telephone connector). **See Figure 43.2 on page 43** for the locations of #1 and #8.
5. Using an 11/32 socket or nut driver, loosen the (6) 8x32 nuts securing the motor and impeller to the housing. Rotate the blower and remove from housing.
6. Holding the black plastic body of the motor, rotate the impeller counter-clockwise until blades line up with opening in the housing and remove motor and impeller.
7. If the gasket between housing and motor is damaged it will have to be replaced. A gasket is included with the replacement blower.
8. Re-install in reverse order.



**Figure 41.1**

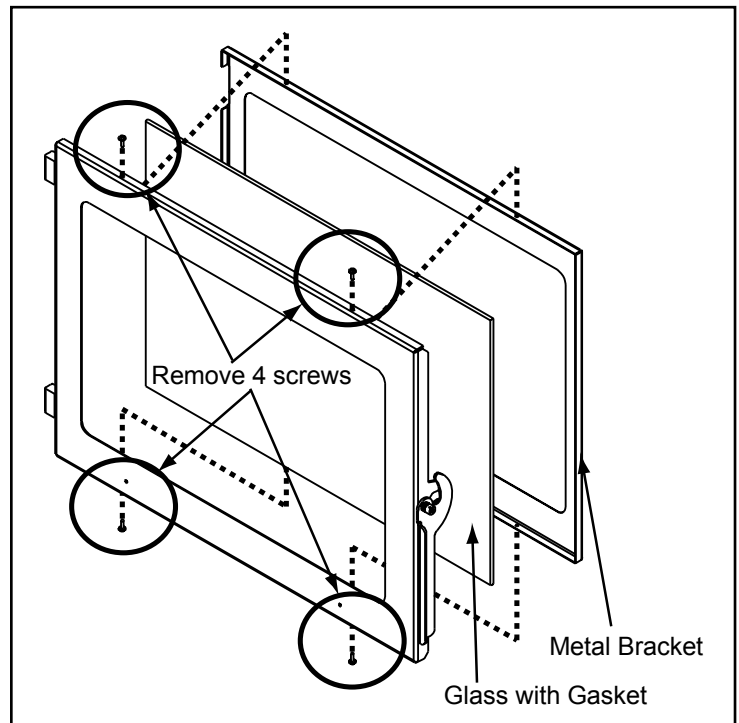
**H. Glass Replacement**

**⚠ WARNING**



- Glass is 5mm thick high temperature heat-resistant ceramic glass.
- **DO NOT REPLACE** with any other material.
- Alternate material may shatter and cause injury.

- a. Swing open the face and remove the door from the appliance by lifting the door off of the hinge pins and lay on a flat surface face down.
- b. Using a Phillips head screw driver, remove 4 screws, 2 on the top and 2 on the bottom. Remove metal bracket and then remove the glass. **Figure 41.2.**
- c. Replace with new glass with gasket.
- d. Re-attach metal bracket with 4 screws.
- e. Re-install door over hinge pins and close face.



**Figure 41.2**

# 11

## Reference Materials

### A. Component Functions



When describing the location of a component, it is always AS YOU FACE THE FRONT OF THE APPLIANCE.

#### 1. Auto-Clean Motor

The auto-clean motor is located under and behind the firepot on the left side, inside the convection air chamber. It automatically opens and closes the firepot floor so ashes can fall into the ash pan.

#### 2. Auto-Clean Switch

The auto-clean switch is located on top of the auto-clean motor. It communicates to the control board when the firepot floor is open and when the auto-clean system has completed its cycle and is back in the home (closed) position.

#### 3. 12 Volt Battery Back-Up Cable (Optional Accessory)

This is an optional accessory. It will plug into the appliance at the rear of the appliance. An icon will display on the wall control when the appliance has lost main power and is running on battery back-up.

#### 4. Combustion (Exhaust) Blower

The combustion (exhaust) blower is mounted in the bottom right rear of appliance. The blower is designed to pull the exhaust from the appliance and push it out through the venting system.

#### 5. Control Board

The control board is located on the lower left side of appliance. It controls the functioning of the appliance and communicates with the wall control. The control board can only be opened by an authorized dealer.

#### 6. Convection Blower

The convection blower is mounted at the bottom left rear of the appliance. The convection blower pushes heated air through the heat exchange system into the room.

#### 7. Door Switch

The door switch is mounted on the right side of the firebox behind the door handle. It senses when the door is open and will display an icon on the wall control, and will turn off the auto-clean system and feed motor for safety.

#### 8. Feed System

The feed system is located on the right side of the appliance and can be removed as an entire assembly. The assembly includes the feed motor, mounting bracket, bearing and feed spring (auger). The hollow feed spring (auger) pulls pellets up the feed tube from the hopper area and drops them down the feed chute into the firepot.

#### 9. Firepot

The firepot is made of high quality ductile iron. The floor of the firepot automatically opens for cleaning and is operated by the auto-clean firepot system. The floor needs to return to a completely closed position or the appliance will not operate properly.

#### 10. Fuses

There are three fuses. Two fuses are located on the inside of the control board. One fuse is AC and operates the igniter and the other fuse is DC and operates all of the other components. The third fuse is located in the power supply. A fuse will blow should a short occur and shut off power to the appliance. The fuses can only be replaced by an authorized dealer.

#### 11. Heat Exchanger

The heat exchanger is located behind the baffle and it transfers heat from the exhaust system into the convection air chamber. Remove the cast iron baffle to access the heat exchanger.

#### 12. Hopper Lid Switch

The hopper lid switch is located on the right side inside the hopper. It senses whether the hopper lid is open and displays an icon on the wall control and will turn off the feed motor.

#### 13. Igniter (Heating Element)

The igniter is mounted on the base of the firepot. Combustion air travels over the red hot igniter creating super heated air that ignites the pellets or other fuels.

#### 14. Low Fuel Indicator

The low fuel indicator is attached to the left side of the hopper. It senses the amount of fuel in the hopper and will display an icon on the wall control.

#### 15. Optical Switch for the Auger

The optical switch is located on top of the feed system and communicates to the wall control that the auger is spinning or if it has stopped.

#### 16. Power Receptacle

The power receptacle is located on the lower rear of the appliance. Check the wall receptacle for 120 volt, 60 Hz (standard current). Make sure the outlet is grounded and has the correct polarity. A good quality surge protector is highly recommended to protect the electronics.

**17. Power Supply**

The power supply is located at the rear of the appliance. It converts 120 volt AC current to 15 volt DC current to power the appliance.

**18. Overheat Sensor (Snap Disc)**

The overheat sensor is mounted on the back of the drop tube in the center of the appliance and has a reset button. To access it remove the right side panel. If the fire tries to burn back into the feed system or push exhaust up the feed tube, this sensor will shut the appliance down, however the wall control will still display messages. This sensor must be manually re-set. Disconnect power before resetting.

**19. Thermocouple - Firepot**

This thermocouple is located on top of the firepot inside the thermocouple cover (ceramic protection tube). The thermocouple sends a millivolt signal to the control board telling the control board there is a fire in the firepot.

**20. Thermocouple - Drop Tube**

This thermocouple is located on the bottom of the drop tube on the right side and attached with a wing nut. It turns the convection blower on and off, varies the speed of the convection blower and will shut down appliance if internal heat exceeds set temperature.

**21. Vacuum Switch**

The vacuum switch is located on the right side of the appliance under the feed motor behind right side panel and connects to the drop tube with a hose. This switch turns the feed system on when vacuum is present in the firebox. The vacuum switch is a safety device to shut off the feed motor if the exhaust or the heat exchanger system is dirty, plugged or if the firebox door is open.

**22. Wall Control Thermostat**

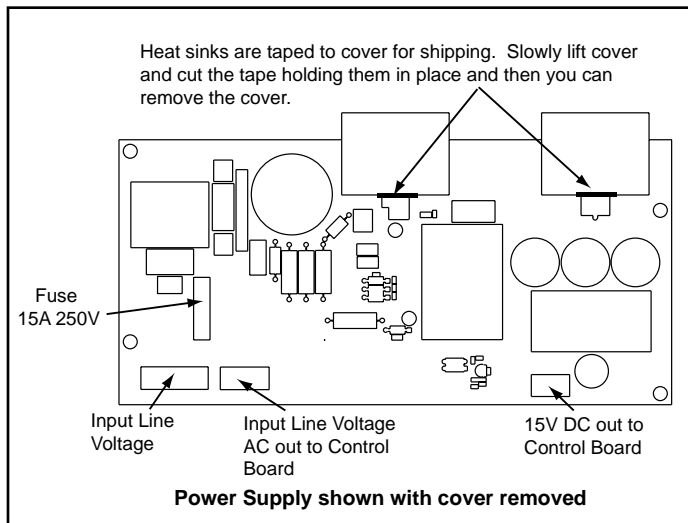
The appliance is designed to run on a custom designed 3.3 volt DC thermostat wall control. It will not operate on any other wall control. Refer to the instructions supplied with the appliance located in the component pack.

**23. Wiring Schematic for Power Supply**

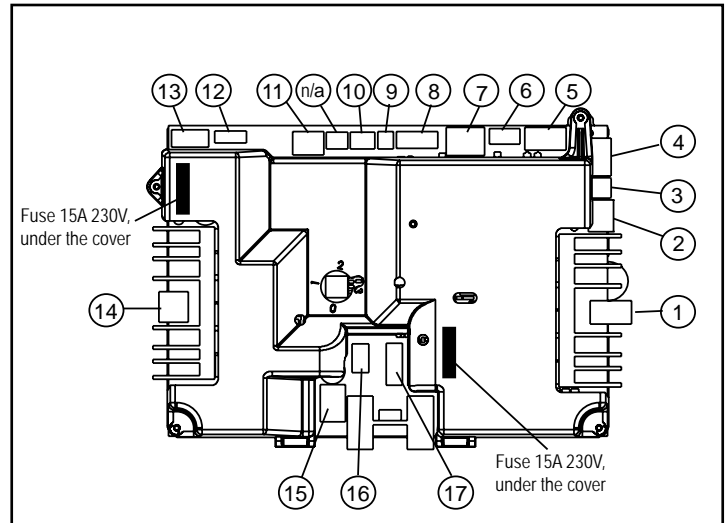
See Figure 43.1 below.

**24. Wiring Schematic for Control Board**

See Figure 43.2 below.



**Figure 43.1 - Power Supply**



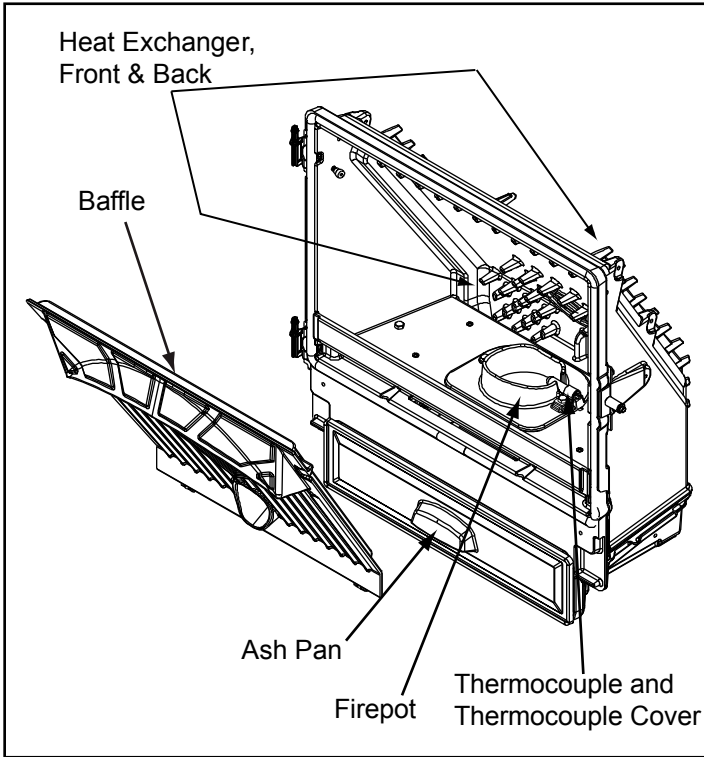
**Figure 43.2 - Control Board**

#	Description
1	Combustion Blower
2	Auto-Clean System
3	Feed/Auger Motors
4	Hopper/Door Switches
5	Auger/Auto-Clean/Vacuum Switches
6	Low Fuel

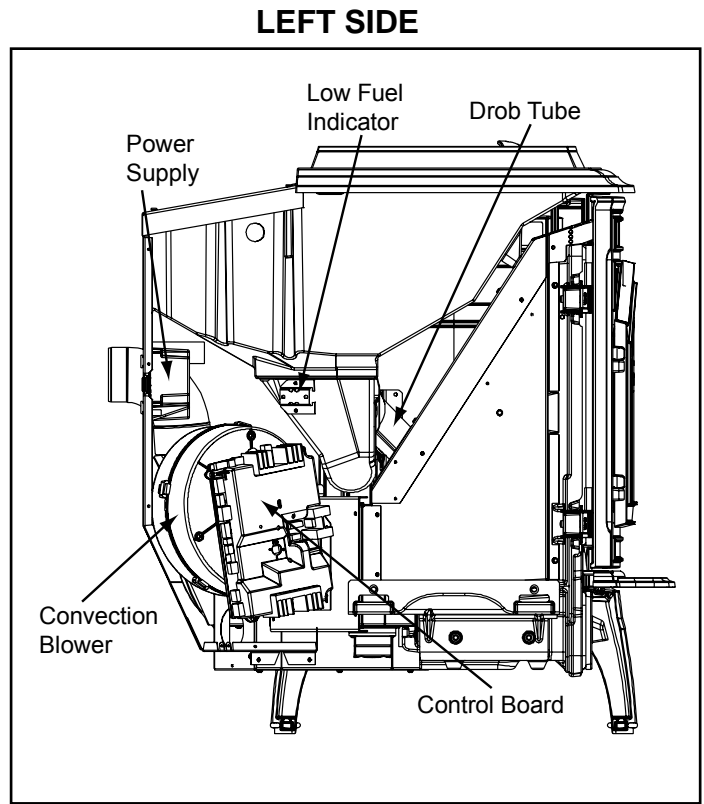
#	Description
7	Thermostat Wall Control
8	Combustion Blower (feedback)
9	Firepot Thermocouple
10	Drop Tube Thermocouple
n/a	Not Used
11	Convection Blower (feedback)

#	Description
12	Igniter
13	AC Power In for Igniter
14	Convection Blower Power
15	Overheat Sensor (Snap Disc)
16	DC Power In from Power Supply
17	12 Volt Battery Back-up

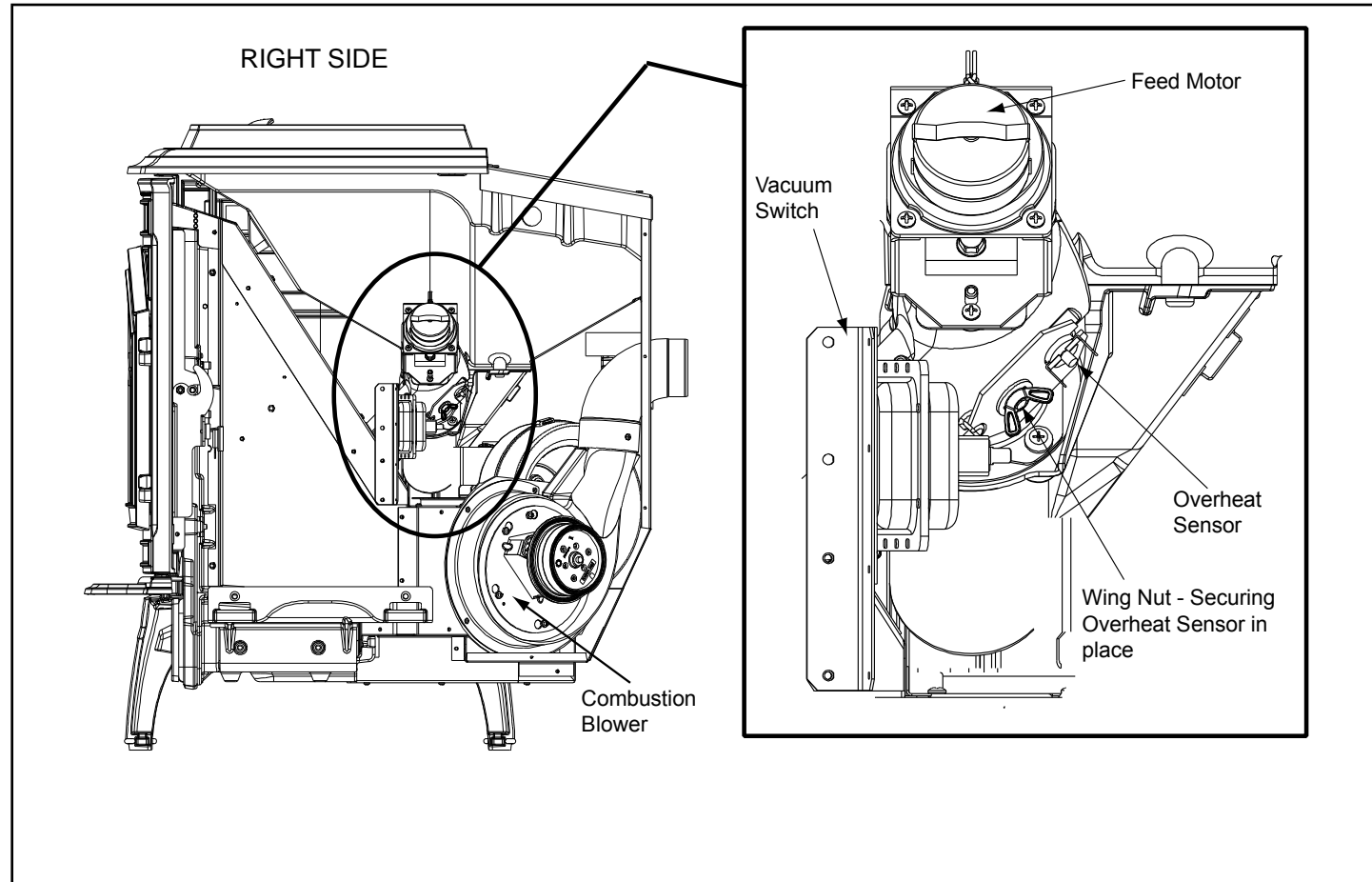
**B. Component Locations**



**Figure 44.1**



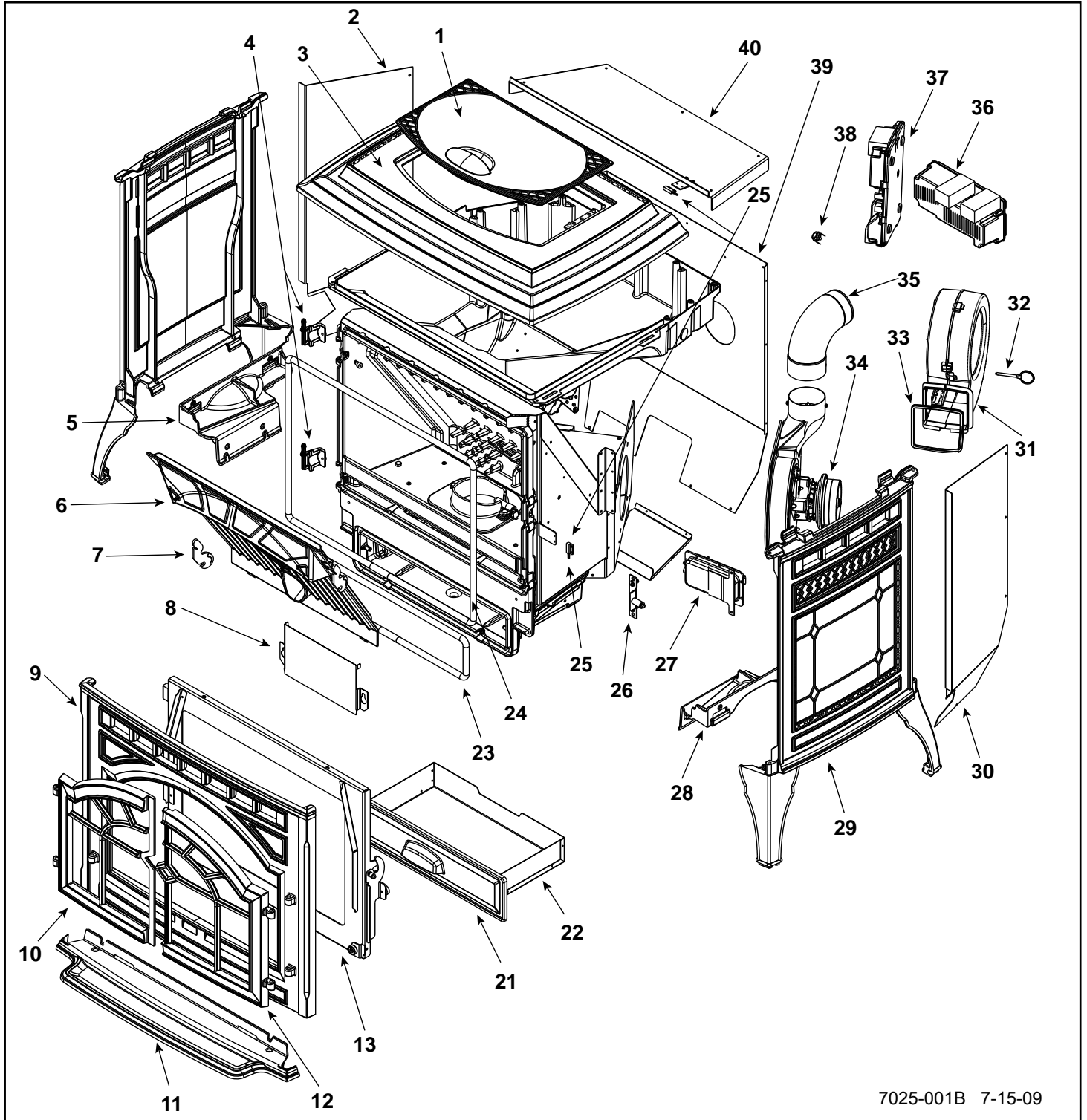
**Figure 44.2**



**Figure 44.3**

**Figure 44.3**

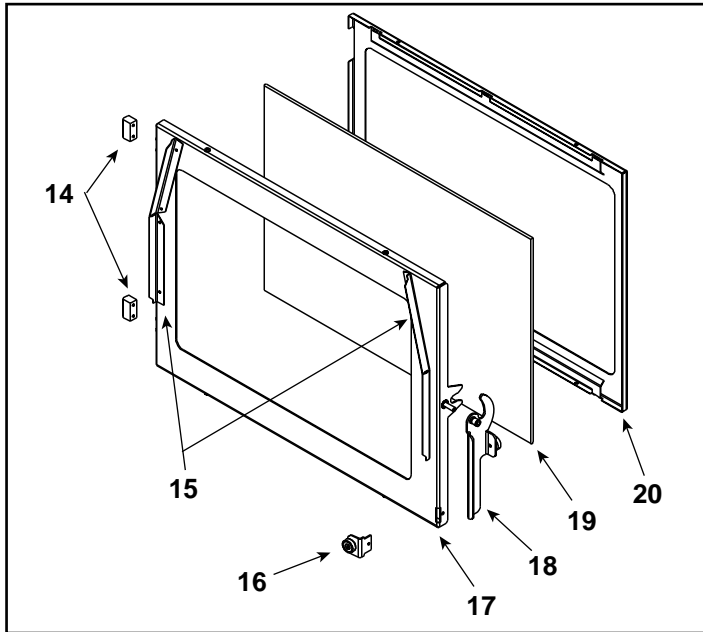
**C. Exploded Drawings**



7025-001B 7-15-09

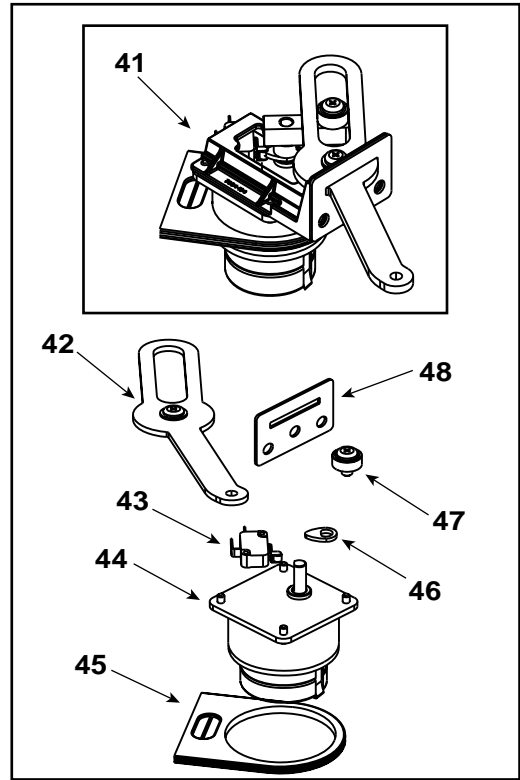
**Figure 45.1**

# 13 Door Assembly

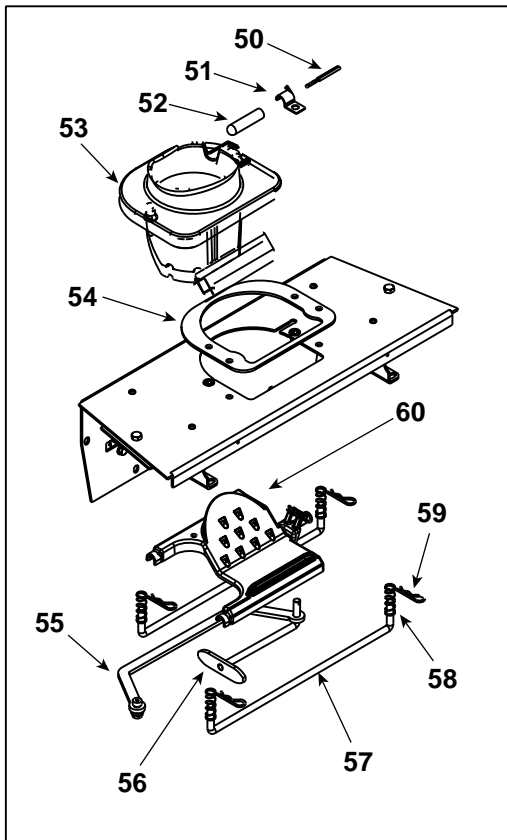


Glass Size: 21 in. W x 14 in. H

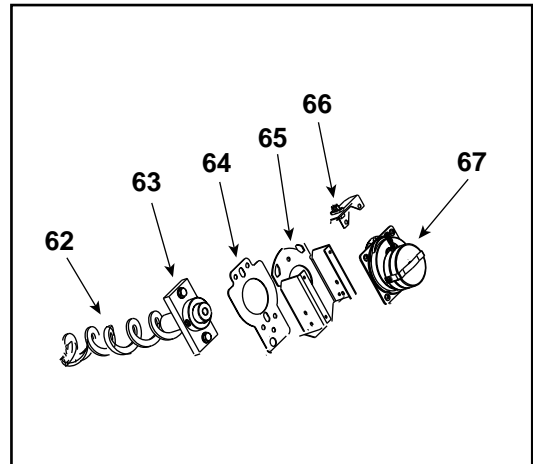
# 41 Auto Clean Motor/Arm Assembly



# 49 Firepot Riser Assembly



# 61 Feed Assembly



Part number list on following pages.

**D. Service Parts and Accessories**

**IMPORTANT: THIS IS DATED INFORMATION**

When requesting service or replacement parts for your appliance please provide model number and serial number. All parts listed may be orderd from an authorized dealer.

**HOW TO ORDER**

To order the entire assembly, order the top line part number only.  
To order an individual part from an assembly, order the part(s) listed in the indented portion.



Item	Description	Comments	Part Number	Stocked at Depot
1	Hopper Lid	Matte Black	7034-157MBK	
		Powder Coat Sienna Bronze	7034-157CSB	
		Powder Coat Willow	7034-157CWL	
		Porcelain Mahogany	7034-157PMH	
2	Shroud Left		7034-172	
3	Top	Matte Black	7034-155MBK	
		Powder Coat Sienna Bronze	7034-155CSB	
		Powder Coat Willow	7034-155CWL	
		Porcelain Mahogany	7034-155PMH	
4	Hinge Male		7034-138	
5	Side Mount Left		7034-128	
6	Baffle		SRV7034-148	Y
7	Latch, Baffle		7034-149	
8	Intake Shield		7034-224	Y
9	Front, Face	Matte Black	7005-108MBK	
		Powder Coat Sienna Bronze	7005-108CSB	
		Powder Coat Willow	7005-108CWL	
		Porcelain Mahogany	7005-108PMH	
10	Door Left	Matte Black	7005-110MBK	
		Powder Coat Sienna Bronze	7005-110CSB	
		Powder Coat Willow	7005-110CWL	
		Porcelain Mahogany	7005-110PMH	
11	Ash Lip	Matte Black	7005-111MBK	
		Powder Coat Sienna Bronze	7005-111CSB	
		Powder Coat Willow	7005-111CWL	
		Porcelain Mahogany	7005-111PMH	
12	Door Right	Matte Black	7005-109MBK	
		Powder Coat Sienna Bronze	7005-109CSB	
		Powder Coat Willow	7005-109 CWL	
		Porcelain Mahogany	7005-109PMH	
13	Door Assembly		7034-006	
14	Hinge, Female		450-2910	
15	Door Air Deflector		7034-185	
16	Magnet Bracket Assembly		7034-008	
	Magnet Round		SRV7000-140	Y
17	Door Frame Assembly		7034-026	

**HOW TO ORDER**

To order the entire assembly, order the top line part number only.  
To order an individual part from an assembly, order the part(s) listed in the indented portion.


**Stocked  
at Depot**

Item	Description	Comments	Part Number	Stocked at Depot
18	Door Latch Assembly		7034-039	
19	Glass Assembly	21 in. W x 14 in. H	7034-007	Y
	Gasket, Channel 3 Mm X 32	Qty: 10 Ft, Field Cut To Size	7000-377/10	Y
20	Glass Retainer		7034-136	
21	Ash Pan Door		7034-133	
22	Ash Pan Assembly		SRV7034-069	
	Twin Ball Catch		SRV7000-532	Y
23	Gasket, Rope, Ash Door		SRV7034-178	Y
24	Gasket, Door Rope		SRV7034-177	Y
25	Magnetic Switch		7000-375	Y
26	Latch Bracket Assembly		7034-049	Y
27	Vacuum Switch		SRV7000-531	Y
28	Side Mount Right		7034-126	
29	Side (Interchangeable)	Matte Black	7005-107MBK	
		Powder Coat Sienna Bronze	7005-107CSB	
		Powder Coat Willow	7005-107CWL	
		Porcelain Mahogany	7005-107PMH	
30	Shroud Right		7034-171	
31	Convection Blower		SRV7000-260	Y
32	Detent Pin	Elbow Catch SN # 00700103644 & Above	7000-393	
		Detent Pin SN # 00700103643 & Below	7000-376	
33	Gasket, Blower, Convection		7000-329	
34	Combustion Blower Assembly		7034-033	Y
	Gasket, Blower, Combustion	Between Housing & Stove	SRV7000-332	Y
	Gasket, Motor, Blower, Combustion	Between Housing & Motor	SRV7000-423	Y
35	Exhaust Transition Assembly		7034-139	
36	Control Board Assembly		SRV7000-456	Y
	Fuse 15A Slow lec Glass	Qty: 10	7000-491/10	
37	Power Supply Assembly		SRV7000-443	Y
38	Snap Disc, Manual Reset	Snap Disc	SRV230-1290	Y
39	Rear Shroud		7034-170	
40	Hopper Top		7034-169	
41	Auto-Clean Motor/Arm Assembly		SRV7034-020	Y
42	Auto-Clean Lever		7034-158	Y
43	Micro Switch No		7000-327	Y
44	Gear Motor 12V		7000-300	Y
45	Grommet, Motor, Auto-Clean		7034-188	Y
46	Cam, Switch, Auto-Clean		SRV7034-187	Y
47	Bearing		7000-333	Y



**HOW TO ORDER**

To order the entire assembly, order the top line part number only.  
 To order an individual part from an assembly, order the part(s)  
 listed in the indented portion.



Item	Description	Comments	Part Number	Stocked at Depot
48	Gasket, Auto-Clean		7034-165	Y
49	Firepot Riser Assembly		SRV7034-002	
50	Thermocouple, K		SRV7034-247	Y
51	Half Clip	Thermocouple Holder	7000-321	
52	Thermocouple Protection Tube	Thermocouple Cover	SRV7034-186	Y
53	Firepot Assembly		SRV7034-010	Y
54	Gasket, Firepot		7034-190	Y
55	Auto-Clean Link Arm		7034-176	Y
56	Plow Weldment, Auto-Clean		7034-024	Y
57	Rail, Auto-Clean		SRV7034-152	Y
58	Spring	Qty: 4	7000-513/4	Y
59	Hitch Pin Clip 3/32	Qty: 10	7000-374/10	Y
60	Firepot Bottom		7034-153	Y
	Auto-Clean Bottom Assembly		7034-021	Y
	Firepot Riser Clamp Assembly		7034-012	
61	Feed Assembly		7034-004	Y
62	Feed Spring Assembly (Only)		SRV7001-046	Y
63	Bearing, Feed System, Nylon		410-0552	Y
64	Gasket, Feed Motor		7034-144	
65	Bracket, Motor, Feed		7034-143	
66	Optical Switch Assembly		7034-038	Y
67	Feed Motor Dc		SRV7000-313	Y
	Collar, Set, 7/8		229-0520	
	Bracket, Control Board		7034-212	
	Bracket, Door Switch		7034-215	
	Bracket, Hopper Switch		7034-216	
	Bracket, Snap Disc		7034-150	
	Bracket, Vacuum Switch		7034-211	
	Component Pack Assembly (Includes Owners Manual, Quick Start Guide, Heat Exchange & Exhaust Cleaning Instructions, Warranty Card, Dvd "How To", Wall Control & Harness, Power Cord, (4) Leveling Nuts & Bolts, Firepot Clean-Out Tool, Touch-Up Paint And Label "If Fireplace Altered")	Matte Black	7034-034	
		Powder Coat Sienna Bronze	7034-035	
		Powder Coat Willow	7034-036	
		Porcelain Mahogany	7034-037	
	Cleanout Tool		414-1140	Y
	Dvd Advanced Energy		7000-335	
	Leveling Assembly		7000-000	

**HOW TO ORDER**

To order the entire assembly, order the top line part number only.  
To order an individual part from an assembly, order the part(s)  
listed in the indented portion.


**Stocked  
at Depot**

Item	Description	Comments	Part Number	Stocked at Depot
	Paint Touch-Up	Matte Black	7000-304	
		Porcelain Mahogany	855-1450	Y
		Powder Coat Sienna Bronze	TOUCHUP-CSB	
		Powder Coat Willow	TOUCHUP-CWL	
	Power Cord		812-1180	Y
	Thermostat Wire 3 Cond		7000-409	Y
	Wall Control		SRV7000-451	Y
	Face Plate	Located Behind ARS Door	7034-124	
	Fuel Level Sensor		7000-380	Y
	Gasket, Exhaust		7034-109	
	Gasket, Extruded	Qty: 10 FT	7000-320/10	
	Gasket, Hopper, Front/Back		SRV7034-236	
	Heating Element Assembly 18" (Loop Igniter)	Qty: 1	SRV7000-462	Y
		Qty: 10	SRV7000-462/10	Y
	Washer, 1/4 Sae	Qty: 24	28758/24	Y
	Wing Thumb Screw 8-32X1/2	Qty: 24	7000-223/24	Y
	Hinge Arm Left	Hopper Lid Bracket	7034-161	
	Hinge Arm Right	Hopper Lid Bracket	7034-160	
	Hinge Pin		72171	Y
	Hinge Retainer	Holds Hopper Lid to Top	SRV7034-163	
	Hinge Pin	Holds Hopper Lid to Top	SRV7034-159	
	Hinge Pin (Rivet) Button Head		25272	
	Thermocouple K, Ring Mount	Drop Tube Thermocouple	SRV7000-381	Y
	Paint, 12 Oz Can	Qty: 1, 12 oz. Sienna Bronze/Espresso	PAINT1-CSB/CES	Y
		Qty: 1, 12 oz. Willow/Tuscan Olive	PAINT1-CWL/CTO	Y
	Roller Catch	SN # 0070010915 & Below	SRV7000-494	Y
	Vacuum Hose	Qty: 3 Ft, Field Cut to Size	SRV7000-373	Y
	Wire Clip	Qty: 10	7000-400/10	Y
	Wire Harness Aug/Ac/Vac		SRV7034-191	Y
	Wire Harness Battery Backup		7034-202	Y
	Wire Harness Convection Blower		7034-219	Y
	Wire Harness Door/Hopper		SRV7034-192	Y
	Wire Harness Ignitor		SRV7034-199	Y
	Wire Harness Power Out Ac	AC Current	7034-220	Y
	Wire Harness Power Out Dc	DC Current	7034-221	Y
	Wire Harness Power Supply Receptacle		SRV7034-233	Y
	Wire Harness Snap Disc		7034-193	Y
	Wire Harness Thermostat		SRV7034-200	Y

**HOW TO ORDER**

To order the entire assembly, order the top line part number only.  
 To order an individual part from an assembly, order the part(s) listed in the indented portion.



**Stocked at Depot**

Item	Description	Comments	Part Number	Stocked at Depot
<b>ACCESSORIES</b>				
	12 Volt Power Cord		12VCORD-AE	Y
	Collar, Offset, Top Vent		812-3570	
	Damper, 3 Inch	Tall Vertical Installs Only	PEL-DAMP3	
	Damper, 4 Inch	Tall Vertical Installs Only	PEL-DAMP4	
	Firescreen		SCR-7005	
	Log Set (2 Pc)	Qty: 2	LOGS-60-AE	
	Log, Front, Left		7034-227	
	Log, Front, Right		7034-226	
	Outside Air Kit		OAK-3	
	Top Vent Adapter		TPVNT-3	
	Vent Adapter, 3-4"		811-0720	
	Vent Adapter, 90, Cleanout		811-0610	
	Vent Adapter, Rear		811-0620	
	Warming Shelves	Matte Black	844-9780	
		Powder Coat Sienna Bronze	WSLG-CSB	
		Powder Coat Willow	WSLG-CWL	
		Porcelain Mahogany	844-9810	
<b>FASTENERS</b>				
	Avk Rivnut Repair Kit	1/4-20 & 3/8-16 Rivnut Tools	RIVNUT-REPAIR	Y
	Button Head 1/4-20 X .5	Qty: 20	32328/20	Y
	Nut, Ser Flange Small 1/4-20	Qty: 24	226-0130/24	Y
	Screw, 1/4-20X3/8 Phillips Button Head	Qty: 24	7000-401/24	Y
	Screw 1/4-20X5/8 Phillips Pan Head	Qty: 24	7000-398/24	Y
	Screw, Pan Head Philips 8-32 X 3/8	Qty: 40	225-0500/40	Y
	Screw, Sheet Metal #8 X 1/2 S-Grip	Qty: 40	12460/40	Y
	Wing Thumb Screw 8-32X1/2	Qty: 24	7000-223/24	Y

**E. Service And Maintenance Log**

Date of Service	Performed By	Description of Service



**Hearth & Home Technologies Inc.  
LIMITED LIFETIME WARRANTY**

Hearth & Home Technologies Inc., on behalf of its hearth brands ("HHT"), extends the following warranty for HHT gas, wood, pellet, coal and electric hearth appliances that are purchased from an HHT authorized dealer.

**WARRANTY COVERAGE:**

HHT warrants to the original owner of the HHT appliance at the site of installation, and to any transferee taking ownership of the appliance at the site of installation within two years following the date of original purchase, that the HHT appliance will be free from defects in materials and workmanship at the time of manufacture. After installation, if covered components manufactured by HHT are found to be defective in materials or workmanship during the applicable warranty period, HHT will, at its option, repair or replace the covered components. HHT, at its own discretion, may fully discharge all of its obligations under such warranties by replacing the product itself or refunding the verified purchase price of the product itself. The maximum amount recoverable under this warranty is limited to the purchase price of the product. This warranty is subject to conditions, exclusions and limitations as described below.

**WARRANTY PERIOD:**

Warranty coverage begins on the date of installation. In the case of new home construction, warranty coverage begins on the date of first occupancy of the dwelling or six months after the sale of the product by an independent, authorized HHT dealer/ distributor, whichever occurs earlier. The warranty shall commence no later than 24 months following the date of product shipment from HHT, regardless of the installation or occupancy date. The warranty period for parts and labor for covered components is produced in the following table.

The term "Limited Lifetime" in the table below is defined as: 20 years from the beginning date of warranty coverage for gas appliances, and 10 years from the beginning date of warranty coverage for wood, pellet, and coal appliances. These time periods reflect the minimum expected useful lives of the designated components under normal operating conditions.

Warranty Period		HHT Manufactured Appliances and Venting							Components Covered
Parts	Labor	Gas	Wood	Pellet	EPA Wood	Coal	Electric	Venting	
1 Year		X	X	X	X	X	X	X	All parts and material except as covered by Conditions, Exclusions, and Limitations listed
2 years				X	X	X			Igniters, electronic components, and glass
		X	X	X	X	X			Factory-installed blowers
			X						Molded refractory panels
3 years				X					Firepots and burnpots
5 years	1 year			X	X				Castings and baffles
7 years	3 years		X	X	X				Manifold tubes, HHT chimney and termination
10 years	1 year	X							Burners, logs and refractory
Limited Lifetime	3 years	X	X	X	X	X			Firebox and heat exchanger
90 Days		X	X	X	X	X	X	X	All replacement parts beyond warranty period

See conditions, exclusions, and limitations on next page.

**WARRANTY CONDITIONS:**

- This warranty only covers HHT appliances that are purchased through an HHT authorized dealer or distributor. A list of HHT authorized dealers is available on the HHT branded websites.
- This warranty is only valid while the HHT appliance remains at the site of original installation.
- Contact your installing dealer for warranty service. If the installing dealer is unable to provide necessary parts, contact the nearest HHT authorized dealer or supplier. Additional service fees may apply if you are seeking warranty service from a dealer other than the dealer from whom you originally purchased the product.
- Check with your dealer in advance for any costs to you when arranging a warranty call. Travel and shipping charges for parts are not covered by this warranty.

**WARRANTY EXCLUSIONS:**

This warranty does not cover the following:

- Changes in surface finishes as a result of normal use. As a heating appliance, some changes in color of interior and exterior surface finishes may occur. This is not a flaw and is not covered under warranty.
- Damage to printed, plated, or enameled surfaces caused by fingerprints, accidents, misuse, scratches, melted items, or other external sources and residues left on the plated surfaces from the use of abrasive cleaners or polishes.
- Repair or replacement of parts that are subject to normal wear and tear during the warranty period. These parts include: paint, wood, pellet and coal gaskets; firebricks; grates; flame guides; and the discoloration of glass.
- Minor expansion, contraction, or movement of certain parts causing noise. These conditions are normal and complaints related to this noise are not covered by this warranty.
- Damages resulting from: (1) failure to install, operate, or maintain the appliance in accordance with the installation instructions, operating instructions, and listing agent identification label furnished with the appliance; (2) failure to install the appliance in accordance with local building codes; (3) shipping or improper handling; (4) improper operation, abuse, misuse, continued operation with damaged, corroded or failed components, accident, or improperly/incorrectly performed repairs; (5) environmental conditions, inadequate ventilation, negative pressure, or drafting caused by tightly sealed constructions, insufficient make-up air supply, or handling devices such as exhaust fans or forced air furnaces or other such causes; (6) use of fuels other than those specified in the operating instructions; (7) installation or use of components not supplied with the appliance or any other components not expressly authorized and approved by HHT; (8) modification of the appliance not expressly authorized and approved by HHT in writing; and/or (9) interruptions or fluctuations of electrical supply to the appliance.
- Non-HHT venting components, hearth components or other accessories used in conjunction with the appliance.
- Any part of a pre-existing fireplace system in which an insert or a decorative gas appliance is installed.
- HHT's obligation under this warranty does not extend to the appliance's capability to heat the desired space. Information is provided to assist the consumer and the dealer in selecting the proper appliance for the application. Consideration must be given to appliance location and configuration, environmental conditions, insulation and air tightness of the structure.

**This warranty is void if:**

- The appliance has been over-fired or operated in atmospheres contaminated by chlorine, fluorine, or other damaging chemicals. Over-firing can be identified by, but not limited to, warped plates or tubes, rust colored cast iron, bubbling, cracking and discoloration of steel or enamel finishes.
- The appliance is subjected to prolonged periods of dampness or condensation.
- There is any damage to the appliance or other components due to water or weather damage which is the result of, but not limited to, improper chimney or venting installation.

**LIMITATIONS OF LIABILITY:**

- The owner's exclusive remedy and HHT's sole obligation under this warranty, under any other warranty, express or implied, or in contract, tort or otherwise, shall be limited to replacement, repair, or refund, as specified above. In no event will HHT be liable for any incidental or consequential damages caused by defects in the appliance. Some states do not allow exclusions or limitation of incidental or consequential damages, so these limitations may not apply to you. This warranty gives you specific rights; you may also have other rights, which vary from state to state. EXCEPT TO THE EXTENT PROVIDED BY LAW, HHT MAKES NO EXPRESS WARRANTIES OTHER THAN THE WARRANTY SPECIFIED HEREIN. THE DURATION OF ANY IMPLIED WARRANTY IS LIMITED TO DURATION OF THE EXPRESSED WARRANTY SPECIFIED ABOVE.

# QUADRA-FIRE®

## CONTACT INFORMATION:

Hearth & Home Technologies  
1445 North Highway  
Colville, WA 99114  
Division of HNI INDUSTRIES

Please contact your Quadra-Fire dealer with any questions or concerns.  
For the number of your nearest Quadra-Fire dealer  
visit our web site at [www.quadrafire.com](http://www.quadrafire.com)

### NOTICE

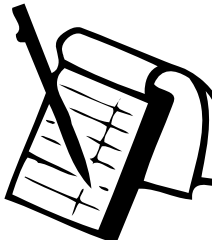


#### DO NOT DISCARD THIS MANUAL

• Important operating and maintenance instructions included.

• Read, understand and follow these instructions for safe installation and operation.

• Leave this manual with party responsible for use and operation.



We recommend that you record the following pertinent information for your MT. VERNON PELLET STOVE (AE)

Date purchased/installed: \_\_\_\_\_

Serial Number: \_\_\_\_\_ Location on appliance: \_\_\_\_\_

Dealership purchased from: \_\_\_\_\_ Dealer phone: \_\_\_\_\_

Notes: \_\_\_\_\_

\_\_\_\_\_

\_\_\_\_\_

This product may be covered by one or more of the following patents: (United States) 4593510, 4686807, 4766876, 4793322, 4811534, 5000162, 5016609, 5076254, 5113843, 5191877, 5218953, 5263471, 5328356, 5341794, 5347983, 5429495, 5452708, 5542407, 5601073, 5613487, 5647340, 5688568, 5762062, 5775408, 5890485, 5931661, 5941237, 5947112, 5996575, 6006743, 6019099, 6048195, 6053165, 6145502, 6170481, 6237588, 6296474, 6374822, 6413079, 6439226, 6484712, 6543698, 6550687, 6601579, 6672860, 6688302B2, 6715724B2, 6729551, 6736133, 6748940, 6748942, 6769426, 6774802, 6796302, 6840261, 6848441, 6863064, 6866205, 6869278, 6875012, 6880275, 6908039, 6919884, D320652, D445174, D462436; (Canada) 1297749, 2195264, 2225408, 2313972; (Australia) 780250, 780403, 1418504 or other U.S. and foreign patents pending.

